

# SINGLE GRIP HANDLE REPLACEMENT INSTRUCTIONS (GEMINI JR.)

## TOOLS REQUIRED

- 7/8" BOX END WRENCH
- 7/16" BOX END WRENCH
- 9/16" BOX END WRENCH
- #3 PHILLIPS HEAD SCREWDRIVER

## INSTALLATION INSTRUCTIONS

1. Press release bar (1) to release "U" handle assembly (2). Lift "U" handle assembly up and push through pivot sockets (3) so that it is parallel to the floor (Figure 1).
2. Using a 9/16" wrench and a 7/8" box end wrench, remove one bolt from each end of the "U" handle. Pull out swivel casters and remove axle spreader (4).
4. Slide "U" handle out through the pivot sockets to remove from the hand truck. Remove the 1/4"-20 x 1-7/8" pan head machine screw from the single grip handle and slide this handle off of the "U" handle. Slide the new single grip handle onto the "U" handle so that it is angled toward the "U" as indicated in Figure 1.
5. Slide "U" handle back through pivot sockets and reassemble the axle spreader and two swivel casters with existing hardware.
6. Rotate "U" handle to vertical position and lower until axle spreader is aligned with locking bracket (figure 2) and lock into place.
7. Position single grip handle by resting the bottom of the handle on the pivot socket with the flat part positioned so that the hole is centered with the main frame (Figure 2).
8. Assemble the 1/4"-20 pan head machine screw with the head on the outside of the handle using a #3 Phillips head screwdriver and 7/16" wrench. Tighten to secure handle.

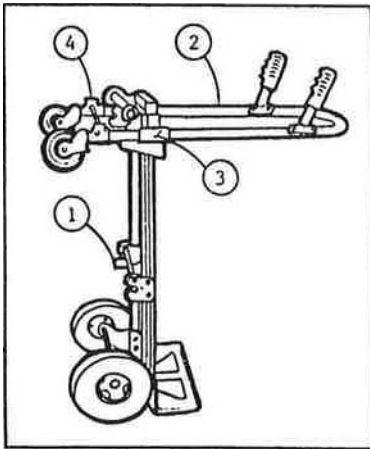

FIGURE 1

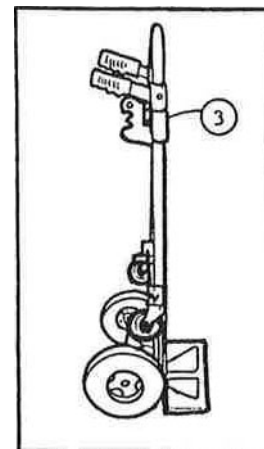

FIGURE 2

**MAGLINER®**

[www.magliner.com](http://www.magliner.com)

Magline, Inc., 1205 West Cedar Street, Standish, MI 48658 • (800) 624-5463 • (989) 512-1000