

GEN I ENCLOSURE UPGRADE

PARTS LIST

Description	Qty.	Part No.
Rubber grommet - 2" dia x 3/32" thick	2	80819

TOOLS REQUIRED

- UTILITY KNIFE
- Ø2" DIA. HOLE SAW & DRILL BIT
- DRILL
- DEBURRING TOOL
- MARKER AND PUNCH

1

Remove the back panel from the enclosure. Carefully measure and place marks (with marker, then with punch) where the center of the hole will be. Use the dimensions shown below.

Rear view, inside enclosure.

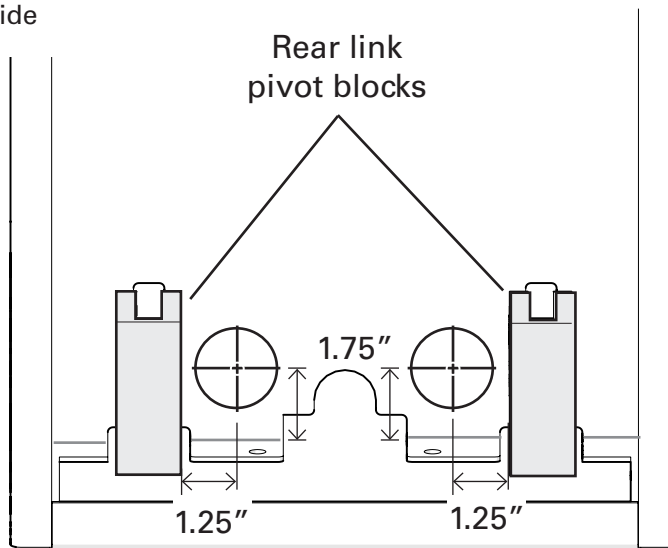

Note: Make sure to measure 1.75" from the lip of the enclosure box, and not from the baseplate.

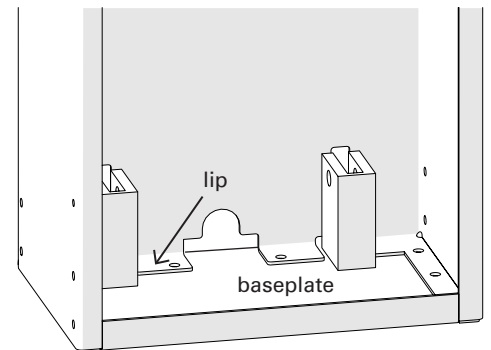

2

Use the drill and hole saw bit to drill two 2" diameter holes. It may be helpful to use a drill bit to drill a pilot hole at the center mark before using the hole saw bit. It may also help to orient the drill bottom-side or battery-side up to obtain the proper angle when drilling the holes. Use the deburring tool to remove any burrs from the hole edges.

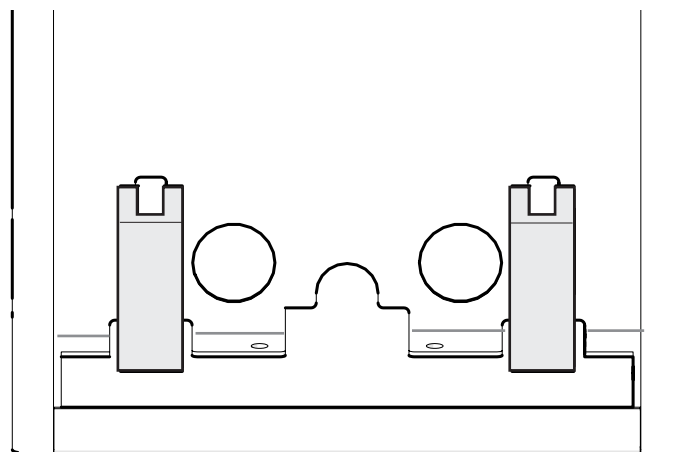

3

Use the utility knife to cut the grommet as shown below.

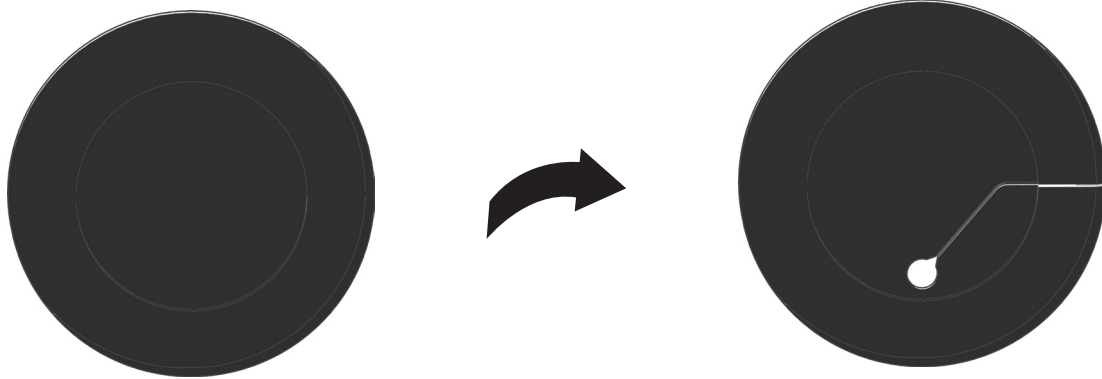

4

Insert the grommets into the holes in the enclosure. Insert the fully-bled brake lines through the holes in the grommets.

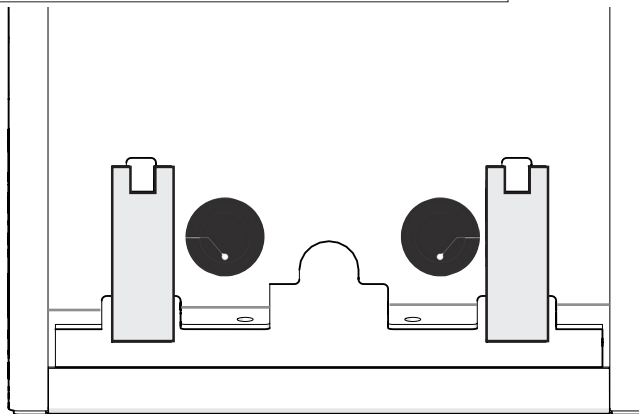

5

Reinstall the back panel.

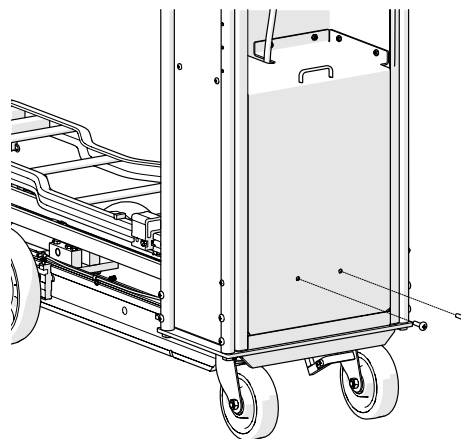

Magline, Inc.

1205 W. Cedar Street • Standish, MI 48658 USA
1-800-MAGLINE (624-5463) • (989) 512-1000 (outside U.S. & Canada)
www.magliner.com