



CooLift[®]

Owner's Manual

For CooLift models CPA43HTC, CPA48HTC and CPA53HTC

IMPORTANT: Read entire manual before operating

Serial #: _____

Date of Purchase: _____

Warranty

Magliner products have a one (1) year warranty (unless otherwise specified) from the date of purchase against defects in workmanship or material. Any part or component, except items covered by warranties of other manufacturers, returned to the factory or service center freight prepaid by the owner, found upon examination by Magline, Inc. to be defective or the result of improper workmanship by the factory will be repaired or replaced without charge and returned to the owner freight prepaid by Magline, Inc.

Alterations of Magliner products void any warranty or liability on the part of Magline, Inc. Magline, Inc. does not guarantee product capacity if alterations are made.

Table of Contents

Introduction, Safety Instructions	4
Operating Labels	5
General Specifications	6
CooLift Pallets	7
Controls -- General Operation	8-12
Battery Instructions.....	13-17
Troubleshooting.....	18-19
Maintenance / Inspection Checklist.....	20-25

Thank you for purchasing the Magliner CooLift! If you have any questions regarding your new Magliner product please call our customer service department at 1-800-MAGLINE (624-5463) or (989) 512-1000. Please read this manual thoroughly to become familiar with the safe operation and maintenance of your new Magliner CooLift.

General Safety Instructions

- Carefully read this entire manual before using your Magliner CooLift.
- Keep hands and feet away from all moving parts.
- Always stand clear of lifting platform area when operating.
- Do not attempt to use the Magliner CooLift on a truck ramp.
- Engage the holding brake whenever in a stopped position.
- Keep the Magliner CooLift in an upright position at all times.
- Do not utilize Magliner CooLift as a lifting device for anything other than a CooLift pallet.
- Do not use the Magliner CooLift to lift or to transport people.
- A routine check of the CooLift should be performed daily that includes, but not limited to: checking for any leaks in the brake system; making sure the containment strap functions correctly; making sure the lift deck raises and lowers smoothly without excessive noise, slowing or shuddering; checking the brake system to ensure proper slowing, stopping, and holding functions.
- Always use the containment strap when moving loads with the Magliner CooLift.
- When transporting a load, always use the handles provided at the user end of the CooLift in order to provide quick access to the braking system should immediate stopping be required.
- Operator should be positioned uphill from CooLift when descending on natural grades, sloping or uneven surfaces.
- Use hand brake to control speed.
- Avoid making sharp turns.
- Always use a Magliner battery charger to charge your battery.
- Do not exceed the pallet capacity limit.
- Brake fluid is a slip hazard on any flooring surface; if a leak occurs it should be cleaned up immediately and completely.
- Do not operate without all guards and safety features securely in place and/or functioning properly.

Please follow the reminder labels found on your Coolift unit.

Coolift Capacity:

1,200 lbs. with 43" Coolift_® pallet
 1,350 lbs. with 46" Coolift_® pallet
 1,500 lbs. with 53" Coolift_® pallet



1-800-MAGLINE (624-5463)

www.magliner.com

Patent: www.magliner.com/patents

Serial No.

12345



**Always stand clear
 of lifting platform
 area when operating**



**Keep hands and feet
 clear of lifting platform**

NO FORK

WARNING:

Raise deck before fastening containment strap

Safety Instructions

- Read and understand operating instructions before using
- Always inspect Coolift and pallets for damage before using. Do not use if there are signs of damage, improper maintenance or load shift
- Do not exceed capacity limit
- **NO RIDING** — Riding on the Coolift could cause serious injury
- **DO NOT USE ON TRUCK RAMPS**
- Use caution on natural grades; operator should be positioned uphill from cart when descending, use brake to control speed, no sharp turns
- Always apply holding brake and lower lift before unloading pallet or leaving Coolift unattended

General Specifications	CPA43HTC	CPA48HTC	CPA53HTC
Corresponding pallet size	43 inch	48 inch	53 inch
Capacity	1,200 lbs	1,350 lbs	1,500 lbs
Weight without battery	280 lbs	280 lbs	272 lbs
Weight with battery	346 lbs	346 lbs	338 lbs
Overall height	60 inches	60 inches	60 inches
Overall width	19 inches	19 inches	19 inches
Overall length	60 inches	60 inches	60 inches
Operating temperature*	-20 to 120°F	-20 to 120°F	-20 to 120°F
Propulsion assist speed	0 - 2.5 mph FWD 0 - 2.5 mph REV	0 - 2.5 mph FWD 0 - 2.5 mph REV	0 - 2.5 mph FWD 0 - 2.5 mph REV

*NOTE: When the outside temperature is below 30°F the Coolift should not be left inside the truck overnight and should never be left inside a freezer or a cooler for extended periods of time. Extended exposure to subfreezing temperatures will adversely affect Coolift battery life.

The Coolift should be stored above 48°F when possible. If the unit is stored in cooler temperatures, the throttle should be exercised to ensure it will return to neutral position when throttle is released.

Battery Specifications

Weight	33 lbs each (66 lbs total)
Voltage	24v (two 12v battery cells)
Battery cells	Sealed lead acid - maintenance free

Fluid Specifications

Brake fluid	DOT 3 or DOT 4
-------------	----------------



Pallets

General Pallet Information:

- Always load within capacity limit.
- Always load within pallet footprint; do not allow load to hang over pallet.
- **CAUTION: When using any multiple load handling system (such as a triple-double) to move the Coolift pallets, do not spread the forks while underneath pallet as it may result in pallet failure.**
- Store in upright position in cool, dry location.
- Do not drop.
- Do not stand upon.
- Wash with mild soap and water.
- Do not use if damaged.
- Make sure to interlock empty pallets when stacking.
- Only stack pallets when empty.
- Do not make modifications to pallet.
- Secure load before transporting.
- Use for intended purpose only.

Sizes	Capacity	Part Number
43" pallet	1,200	309344
48" pallet	1,350	309345
53" pallet	1,500	309346

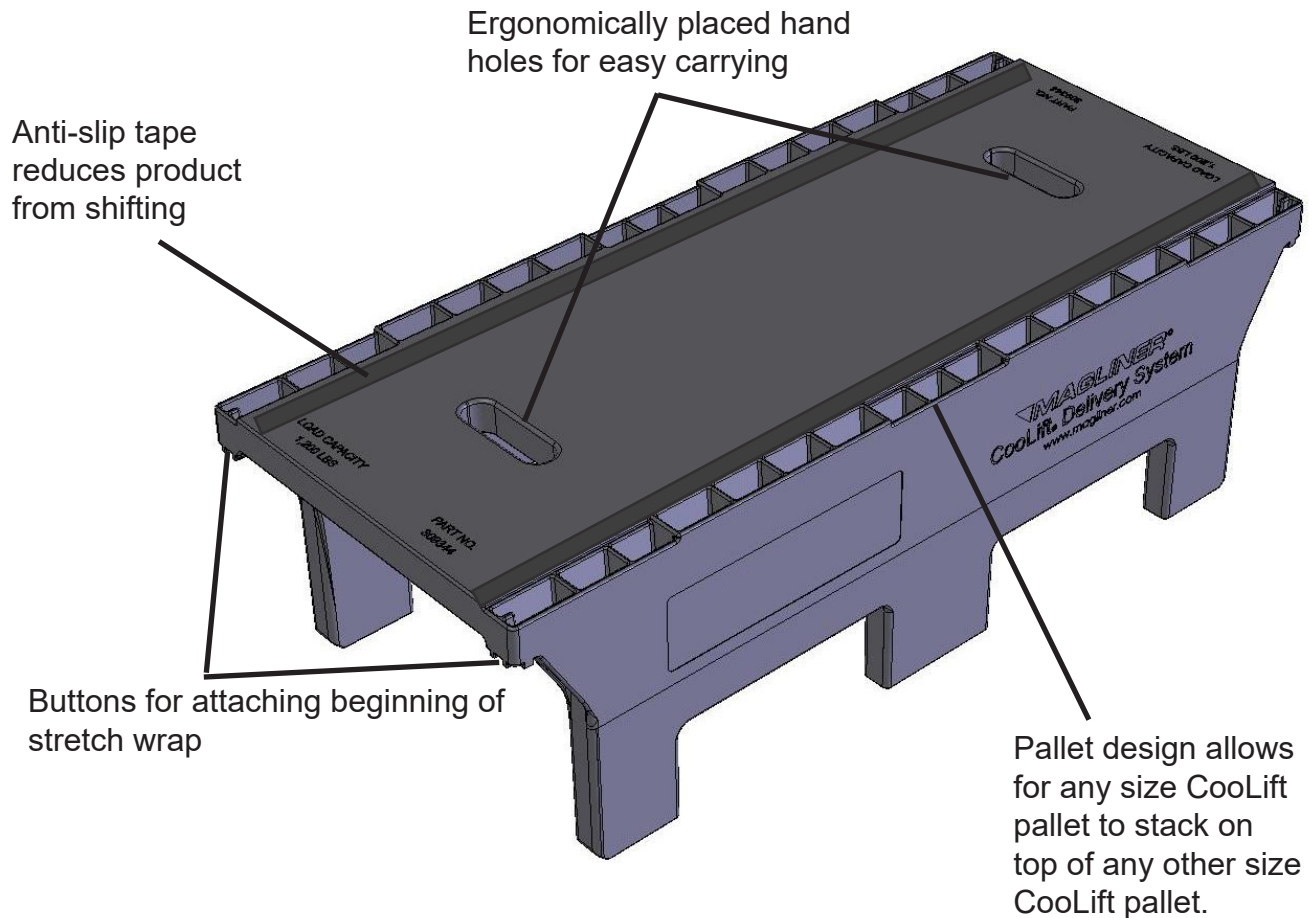

User Controls

- A) Main Power Switch – provides power to the unit for raising and lowering the deck.
- B) Circuit Breaker – helps to protect the components should an electrical short or overload occur.
- C) Propulsion Power Switch - provides power to the unit for using the propulsion assist feature.
- D) Battery Meter – indicates level of charge in batteries.
- E) Deck Positioning Switch (up/down) – used to raise and lower the lift deck.
- F) Directional Switch (forward/reverse) - used to set direction for propulsion assist feature.
- G) Brake Lever – used for slowing and stopping the momentum of the CooLift.
- H) Holding Brake Latch – used to keep the CooLift from rolling inadvertently – **Always engage holding brake whenever CooLift is unattended.**
- I) Cord Storage Brackets – holds the AC built-in battery charger input cord when not in use.
- J) Containment Strap – should be used to secure loads during transport.
- K) Throttle - used to control speed for propulsion assist feature.
- L) Folding Lift Assist Handles (optional) - provides ergonomic lifting solution when leverage is needed for removing CooLift from under pallet/overcoming thresholds.

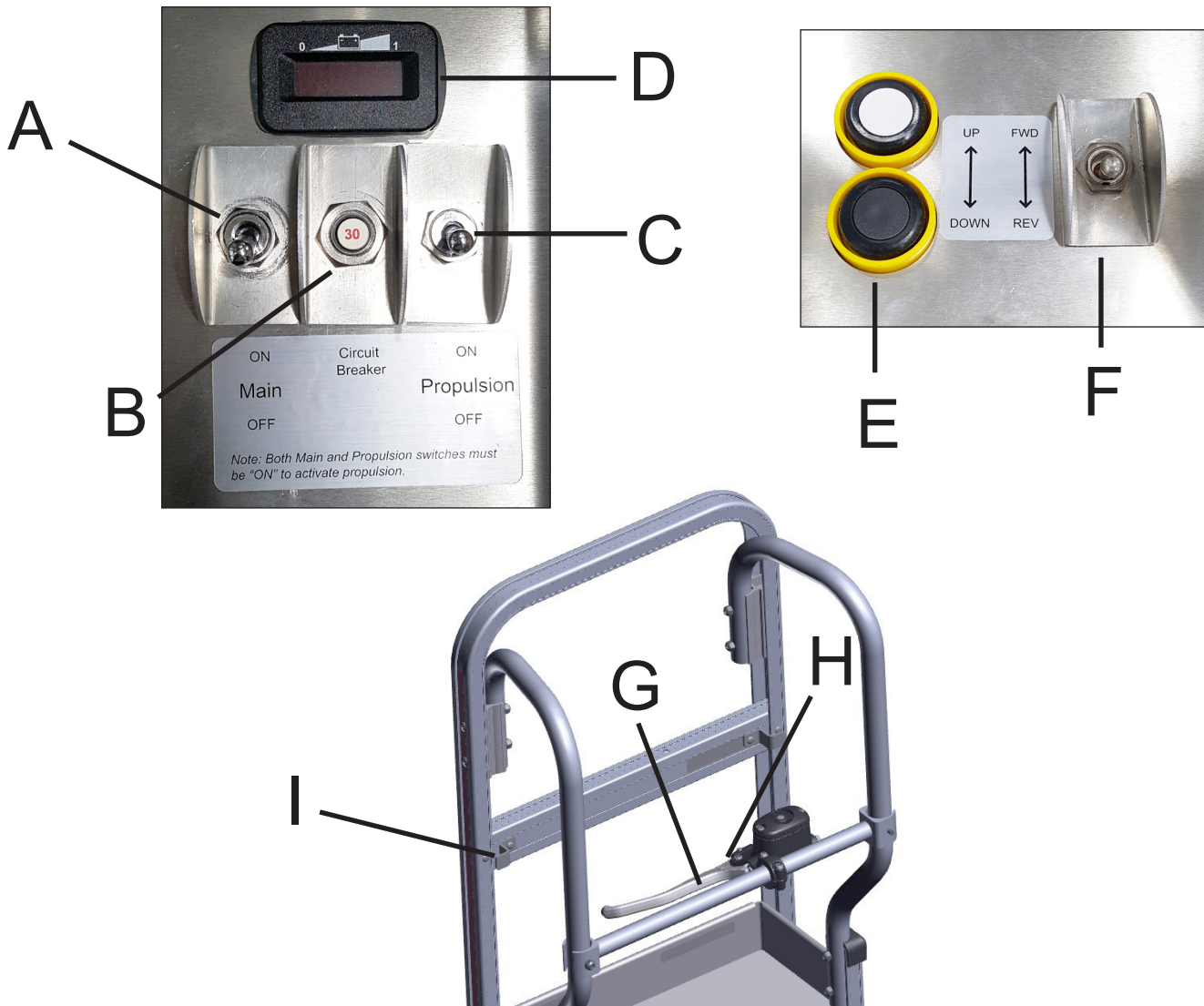



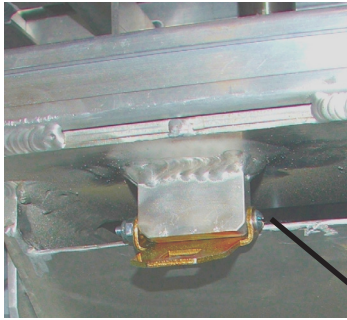

Front Underside View



CooLift with product strapped to deck

General Operation of the Magliner CooLift

A) Storage and Limited Use of Holding Brake

- 1) Engage the holding brake whenever leaving the CooLift unattended.
- 2) Pallets on the Magliner CooLift should always be in the down position when not moving.
- 3) Keep hands, feet and all items clear of the moving parts of the CooLift.
- 4) Never place hands or feet under a loaded elevated pallet.
- 5) The holding brake is intended to be used for limited periods of time only.
- 6) Store the CooLift on a hard level surface.

B) Loading a pallet on the Magliner CooLift

- 1) Make sure CooLift deck is in down position.
- 2) Push the CooLift under the pallet until fully inserted and the back of the pallet is touching the enclosure (CPA53HTC), bulk head (CPA48HTC) or pallet stops (CPA43HTC).
- 3) Press and hold the up switch until the lift deck is fully raised (this is noticeable by the sound changed of the running hydraulic pump and the stop of upward motion of the pallet).
- 4) Engage the holding brake by depressing the brake lever back toward the horizontal handle with one hand and flipping the holding brake latch into one of the provided notches to hold it in place.

Note: Make sure the deck is in the up position prior to fastening the containment strap.

- 5) Fasten the containment strap to secure the load by: a) firmly grasping the end of the strap; b) pulling it out from the roll directly over the center of the load taking care not to twist the strap; c) extending strap far enough to snap into position; and d) hooking strap to the containment lock located at the lower front end of the cart (see Front Underside View).
- 6) The maximum stacking height for all models (CPA43HTC, CPA48HTC, and CPA53HTC) models is 50" from the floor. However, never stack a load that is higher than your line of vision.



Figure 1: CooLift secured under a loaded pallet with the holding brake engaged



Figure 2: CooLift strapped into truck for transport

C) Transporting a pallet with the Magliner CooLift

- 1) When transporting a pallet with the CooLift the operator should always use caution on natural grades. Be positioned uphill from cart when descending, use brake to control speed and make no sharp turns.
- 2) Care should be taken to address any sidewalk ramps or door thresholds to help maintain stability in the load.
- 3) Use caution at all sloping or uneven surface areas and make any final positioning changes.
- 4) Depress the down switch and hold it until the CooLift deck has lowered completely. Note: it is possible to have the pallet sitting on the floor and the deck still engaged to the bottom of the pallet if the deck has not been completely lowered.
- 5) Remove the CooLift from under the pallet.

D) Unloading a pallet from the Magliner CooLift

- 1) Position the cart in place on a level surface and engage the holding brake.
- 2) Lower the deck completely.
- 3) Unlock the containment strap from the lock by lifting the tab and sliding the latch out.
- 4) Walk the strap back into position on the roll.
- 5) Disengage the holding brake by pulling the brake lever back until the latch releases.
- 6) Pull CooLift out from under pallet

E) Transporting the Magliner CooLift inside the truck

Note: It is important to keep the CooLift upright at all times.

- 1) If you are transporting the CooLift on a truck that has loaded pallets, insert the CooLift completely under a fully loaded pallet and toggle the up switch until the lift deck makes contact with the bottom of the pallet but does not lift and engage the holding brake (Figure 1).
- 2) If there are no loaded pallets on the truck, the CooLift should be parked next to the wall and strapped in with the holding brake engaged (Figure 2).

- F) Using the Variable Speed Propulsion Assist Feature
- 1) Turn both the Main and Propulsion power switches to the “On” position.
 - 2) Use the directional switch to indicate either forward or reverse movement. The unit can be driven forward when the switch is pushed upward or in the middle position. The switch must be pushed backward for reverse.
 - 3) Slowly pull the throttle lever to begin motion.



Throttle

General Propulsion Assist Warnings:

- Do not use propulsion assist when in confined spaces.
- Be sure there are no obstacles or people in front of the CooLift before activating propulsion.
- Check to be sure the path is clear.
- Check behind you for obstacles or people before using the propulsion assist in reverse mode.
- Keep both hands on the CooLift handles while using the propulsion assist feature.

General Battery Warnings:

- Do not connect accessories to the battery; this will cause premature battery failure or possible damage to the batteries.
- Unauthorized modification could create a hazardous condition and result in serious injury.
- Batteries contain acid, which can burn eyes, skin, clothes, etc. Use caution! Always wear gloves when working with batteries. If contact occurs, flush immediately with water and get medical attention. Protect surfaces from battery damage by placing batteries on rubber or plastic surfaces.
- To prevent electrical shock, do not touch non-insulated parts of the charger output connectors, battery connectors or battery terminals. Do not use connectors that are cracked, corroded, or do not make adequate electrical contact. Use of damaged or defective connectors could result in fire or electrical shock.
- Keep sparks, flame and smoking materials away from batteries.
- Batteries can supply a large amount of current. Do not wear jewelry or watches when working on the batteries as an accidental shorting could occur and cause severe burning.
- Only qualified technicians should service your Magliner CooLift power supply system.
- Disconnect the batteries by unplugging the main wiring harness at the control board before attempting to replace any electrical components.
- Only use authorized Magliner CooLift replacement parts.



Battery Life

The Magliner CooLift is powered by two 12-volt storage batteries. The lift and propulsion motors draw current from the batteries based on the amount of effort required to meet load being lifted. Testing and research has been done to ensure a fully-charged battery will allow the user to go through two days of single-shift operation without recharging the system. This amounts to a total of over 500 lift cycles and traveling 3 miles with propulsions. However, extreme temperature ranges and extreme loads can have an effect on the amount of power available during one charging cycle.

NOTE: The battery must be charged within 3 months of storage to prevent self-discharge. If the battery is not charged within 3 months of storage, permanent loss of capacity may occur.

If the CooLift will be used regularly, it is recommended that the unit be kept on a charger whenever it is not in use; the batteries will not overcharge. If the CooLift is going to be stored and/or not in regular use, the batteries must go through a full charge cycle every 2 weeks to ensure battery life and duty cycle.

*Battery has a warranty of six (6) months.

Battery Charging

A built-in Magliner AC charger (part #3098781) when using a common 120v domestic or 230v international outlet is capable of safely charging your Coolift battery. This charger uses standard household power.



Battery Charging Warnings:

- ✓ Use only Magliner chargers designated for use with Coolift.
- ✓ Do not expose charger to excessive rain or snow.
- ✓ To prevent risk of fire, use the charger only in a dry, well ventilated room without flammable fluids or explosive gases.
- ✓ Do not allow clothing, blankets or other material to cover battery charger during charging process. Even though the charger has an internal temperature gauge and will not function if the temp gets too hot, as a precaution, keep any highly flammable objects away.
- ✓ Use of an attachment not recommended or delivered by the battery charger manufacturer may result in a risk of fire, electric shock or injury to persons.
- ✓ Avoid using an extension cord as it can present risk of fire and electrical shock. Never use a household extension cord if the charger plug does not reach outlet. If an extension cord must be used, use a three conductor No. 14 AWG (or heavier) cord with proper ground, in good electrical condition and kept as short as possible.
- ✓ Make sure the cord is located such that it will not be a trip hazard or otherwise subject to damage or stress.
- ✓ Do not operate a charger with a damaged cord or plug – replace immediately.
- ✓ Do not operate a charger if it has received a sharp blow, been dropped, or otherwise subjected to damage or stress.
- ✓ Do not disassemble the charging unit.
- ✓ To reduce risk of electrical shock, unplug the charging unit from the AC power supply source before attempting any maintenance or cleaning.
- ✓ Always unplug the charging unit before operating the Magliner Coolift.
- ✓ Always use battery chargers supplied by Magline, Inc. Other battery charging units could cause damage to your batteries or personal injury.
- ✓ Batteries generate gases that can be explosive. If an interruption of the charging cycle is desired, simply disconnect the charger from the power supply source at the wall outlet.
- ✓ To avoid damage to battery charger connectors and cords, disconnect the plug by grasping the plug body and pulling it straight out of the wall outlet. DO NOT pull on the cord. DO NOT twist, rock, or pull the connector sideways.
- ✓ The metal tip on the end of the plug may be hot when it is first unplugged.

Using the AC Charging Unit

Note: A completely drained 40Ah battery can take up to 8 hours to fully charge.

1. To charge the Coolift, connect the AC charger plug to an AC outlet (120v domestic or 230v international).
2. The batteries may be charged as often as desired. Magline recommends charging at least once after each delivery route is complete.

NOTE: Each positive and negative wire from each charging bank has a 7.5A fuse.

AC Charging Unit LED Indicators

The flashing red lights indicate the charging phase while the batteries are charging.

- 1 bar = 0-25% charged. The light will turn solid when 25% charge is reached, and the next light will begin to flash.
- 2 bars = 25-50% charged. The light will turn solid when 50% charge is reached, and the next light will begin to flash.
- 3 bars = 50-75% charged. The light will turn solid when 75% charge is reached and the next light will begin to flash.
- Flashing green light + 3 red light = 75-95%, this DOES NOT mean fully charged.
- Maintenance mode (flashing green + 0 red lights) = 95-100%, means battery is optimizing the charge going into the battery, which ensures the battery is not overcharged. This prolongs battery life.
- Solid Green light = 100% fully charged



Charging notes: If batteries are fully charged and the charger is plugged in, the charger light will run through the entire cycle (1 red bar, 2 red bars, 3 red bar etc). This can take up to 3-5 minutes to go through the cycle; do not assume the charger did not charge the batteries. The charger constantly reads the batteries to determine optimal charging behavior. Wait several minutes for the charger to properly read the batteries.

Other Charger LED Indicators

These two orange power lights can mean 2 possible things.

1. Press buttons 1 and 2 until the desired mode light is illuminated. The correct mode for your model is stated below.
2. There is an error in the connection with the batteries. This will show when the charger cannot read a connection between the batteries, and pressing buttons 1 & 2 do nothing. Possible causes are loose terminal(s), wire or fuse disconnect, or a faulty battery bank. If lights light up, this means that power is being supplied to the charger, but not to the batteries.



The white lights indicate the mode the charger is in either 12V Standard, AGM, Lithium or repair mode. The modes are selectable using buttons 1 & 2 once the charger is plugged in and the orange icons light up. Below are the following modes, and which mode should be selected.

- 12V Standard is used for a general range of battery types. **Select this mode for Coolift models with propulsion assist (models beginning in CPA).**
- AGM mode used for certain AGM batteries.
- Lithium mode is for lithium batteries (not available for Coolift units).
- Repair mode will be used if a battery is showing less than 1 volt. Repair mode will not fix all battery problems. To use repair mode, hold down buttons 1 & 2 for at least 3 seconds.



Error LED Indicators

Solid - Charger is in Standby mode or battery voltage is too low for charger to detect.



Solid - Battery voltage is too high for the selected charge mode. Check the battery and charge mode.



Solid - Possible battery short / battery will not hold a charge. Contact Magline.



Solid - Reverse polarity. Reverse the battery connections.



Flashing - Charger internal temperature too high - Charger will resume function once the charger internal temperature drops, OR

Charger ambient temperature too cold - Charge will resume function once the charger ambient temperature rises.

Battery Meter Operating Instructions

- Battery meter will show the charged state of the battery whenever the main power switch is turned ON
- During normal operation, the charged state of the battery is indicated by the number of bars displayed on the meter
 - Full charge is 10 steady bars
 - A partial charge is two to nine steady bars
 - A low battery is two alternately flashing bars
- While the battery charger is plugged in and charging the battery, the display will repeatedly scroll across the bars up to the level of charge in the battery
 - Full charge is indicated by scrolling across 10 bars
 - A partially charged battery is indicated by scrolling across two to nine bars
- When the main power switch is OFF, the battery meter will not display

Troubleshooting - CPA Models

Problem	Possible Causes	Remedy
The unit does not turn on.	Main power switch	Make sure the main switch is turned on.
	Battery power	Make sure the batteries are charged.
	Circuit breaker	Check the circuit breaker; if it has been tripped, reset it.
	Electrical connections	Check electrical connections for tightness, including battery terminals within the enclosure.
The Coolift is not charging up.	Charger	<p>Make sure that the charger is working correctly.</p> <p>Make sure the charger is in the correct mode. All Coolift CPA models need the NOCO charger set to 12V Standard.</p> <p>Make sure there is no damage to the plug or cord; replace any damaged items.</p> <p>Make sure the power plug is plugged into the charger socket.</p> <p>Make sure the charger output cord is plugged into the batter pack charger port.</p> <p>Abbreviated information below; See pages 15-17 of the Owners Manual for complete charger information.</p>
	Electrical connections	Check electrical connections for tightness, including battery terminals within the enclosure.

AC Charging Unit LED Indicators

The flashing red lights indicate the charging phase while the batteries are charging.

- 1 bar = 0-25% charged. The light will turn solid when 25% charge is reached, and the next light will begin to flash.
- 2 bars = 25-50% charged. The light will turn solid when 50% charge is reached, and the next light will begin to flash.
- 3 bars = 50-75% charged. The light will turn solid when 75% charge is reached and the next light will begin to flash.
- Flashing green light + 3 red light = 75-95%, this DOES NOT mean fully charged.
- Maintenance mode (flashing green + 0 red lights) = 95-100%, means battery is optimizing the charge going into the battery, which ensures the battery is not overcharged. This prolongs battery life.
- Solid Green light = 100% fully charged



Normal Charging Lights



Correct Charger Mode

Troubleshooting - CPA Models

Problem	Possible Causes	Remedy
The pump runs and will not shut off.	Circuit continuity	Turn off main power switch. Check the continuity of the starter solenoid. Check the continuity of the operator on/off switch.
The pump is running but the deck is not lifting.	Reservoir	Make sure the reservoir has the correct level of fluid. Make sure the breather cap for the reservoir is plugged. Make sure the manual pump release valve is open.
	Hydraulic lines	Check for leaks in the hydraulic system; replace damaged components.
Deck lifts but then gradually lowers with and without a load.	Pump release valve	Be sure valve is secured tightly in the pump housing using a ¾" or 21mm wrench, be sure release valve is in the closed position (turn clockwise until snug).
	Hydraulic lines	Check for leaks in the hydraulic system; replace damaged components.
The deck lifts OK but lowers slowly.	Hydraulic lines	Does it go down more quickly when opening the manual release valve? Check for leaks in the hydraulic system; replace damaged components.
The deck lifts slower than usual.	Reservoir	Be sure the pump has the correct amount of fluid. (ISO32 Hydraulic fluid). 16 oz. max for a full system. Fluid level needs to be ¾" from the bottom of the fill plug. (Fluid available through Magline or most automotive retailers).
	Hydraulic line	Check the line for and cuts or damage. Replace as needed. See Part# 55424.
The deck is in the up position and will not go down.	Linkage System	Check for and remove any foreign matter in the linkage system. Check to be sure the pins or linkage aren't rubbing or binding.
	Electrical connections	Check electrical connections for tightness.
	Manual pump handle	Use the manual pump handle to lower the deck (the manual pump handle is stored inside the enclosure).

Troubleshooting - CPA Models

Problem	Possible Causes	Remedy
The brakes are not working or braking unevenly side to side.	Brake fluid	<p>Check for leaks in the brake lines; replace damaged components.</p> <p>Make sure the brake reservoir has the correct level of fluid.</p> <p>Sometimes pumping the brake lever several times corrects the issue.</p>
	Brake mounting	<p>Make sure both of the calipers mounted tightly to the rail?.</p> <p>Make sure the brake discs are running true and mounted properly.</p> <p>Check to see if disc mounting screws have not backed out; tighten or replace as necessary.</p>
Hydraulic or brake fluid has dripped into the drip pan underneath the CooLift deck.	Lines	Check for leaks in the hydraulic or brake system; replace damaged components.
	Cleanup	Wipe up any fluid that may have leaked into the drip pan using shop towels.
The propulsion assist feature is not operating (continued on next page).	Battery power	Make sure the batteries are charged.
	Power switches	Ensure both the lift system and propulsion system switches turned to the ON position.
	Cycle reset	<p>Fully lower the deck and turn both the Main power and propulsion system switches to the OFF position.</p> <p>Wait 2-3 minutes and turn the lift system and propulsion system switches to the ON position.</p>
	Electrical connections	<p>Is the jumper wire harness connected to the main wiring harness? This part of the main wiring harness consists of two red wires.</p> <p>Check to make sure the wires to the throttle connected, both in the enclosure and on the handle.</p> <p>Check for loose wire connections from the controller or battery.</p>

Troubleshooting - CPA Models

Problem	Possible Causes	Remedy
The propulsion assist feature is not operating (continued from previous page).	Brake	Make sure the parking brake is released.
	Chain drive	Check the chains in the propulsion system to see if they are in place and tensioned properly. Remove any debris in the chains or in other parts of the propulsion system.
	Throttle behavior	Make sure the throttle is returned fully to its neutral position before pushing the throttle; this gives the clutch time to engage. When changing direction, fully release the throttle to neutral position and incorporate a slight pause before moving the throttle for the opposite direction; this gives the clutch time to engage.

Required Maintenance Procedures and Inspection Log

Cart Serial No: _____ Maintenance Date: _____
 Customer: _____ Completed By (name): _____

Area	Related Components	Maintenance Instructions	Frequency	Notes
Lift System	Entire system	<ul style="list-style-type: none"> • Lift deck to its fully raised position • Remove cover protecting the propulsion system. • Turn off CoolLift • Check for and remove all debris including on screws and around the lift chain assembly 	Every 2 Weeks	
Lift System	Limit Switch	<ul style="list-style-type: none"> • Lift deck to its fully raised position • Check the lower limit switch by pressing the metal tab gently toward its black box; it should respond by snapping quickly back into place • Now lower the deck to its fully lowered position. • Check the upper limit switch by pressing the metal tab gently toward its black box; it should respond by snapping quickly back into place 	Monthly	
Lift System	Acme lead screws	<ul style="list-style-type: none"> • Lift deck to its fully raised position • Turn off CoolLift • Apply a lithium-based grease to the lead screws • Brush the grease evenly across the threads • Turn on the CoolLift; run deck up and down a few times to distribute grease 	Monthly	
Lift System	Lift chain (front of deck) lubrication	<ul style="list-style-type: none"> • Lift deck to its fully raised position • Turn off CoolLift • Oil chains lightly with a 40 weight (or greater) oil. Moly chain lubricant may be used as a substitute. 	Monthly	
Lift System	Lift chain (front of deck) tension	<ul style="list-style-type: none"> • Lift deck to its fully raised position • Turn off CoolLift • Chain should have 1/8" side-to-side play between sprockets when you push on it • To adjust, loosen or tighten the 3-1/4" long socket head cap screws in the mount plate until 1/8" play in chain is reached 	Monthly	

Area	Related Components	Maintenance Instructions	Frequency	Notes
Propulsion System	Drive chain lubrication	<ul style="list-style-type: none"> • Lift deck to its fully raised position • Remove cover protecting the propulsion system • Turn off Coolift • Oil chains lightly with a 40 weight (or greater) oil. Moly chain lubricant may be used as a substitute. 	Monthly	
Propulsion System	Drive chain tension	<ul style="list-style-type: none"> • Lift deck to its fully raised position • Turn off Coolift • Chain should have 1/4" side-to-side play between sprockets when you push on it • To adjust, loosen or tighten the 5/16" - 18 x 2" long socket head cap screws in the mount plate until 1/4" play in chain is reached 	Monthly	

Cart Serial No: _____ Inspection Date: _____

Customer: _____ Inspector's Name: _____

Estimated Usage: _____

Area	Description	Method of Inspection	Normal Condition	Findings Pass or Fail	Timing	Notes
General Inspection	Cart is straight and properly aligned	Visual inspection	<ul style="list-style-type: none"> • Frame is not twisted or bent • User enclosure is perpendicular to the frame • Deck is angled slightly toward enclosure when retracted • Handles are not bent or damaged 		Daily	
General Inspection	No damage or excessive wear	Visual inspection	<ul style="list-style-type: none"> • Straight sections • Smooth curves • Flat surfaces 		Daily	
General Inspection	Cart rolls smoothly	Push cart and let roll	Cart should travel in nearly a straight line for several feet		Daily	
General Inspection	Brakes are responsive when applied	Roll cart at walking speed and apply brakes	<ul style="list-style-type: none"> • Brakes should feel responsive and not "soft" • Brake lever should not contact handle 		Daily	
General Inspection	Holding brake remains active over time	Lock brakes for 10 minutes then push on cart with brake still locked	Brake should remain engaged		Daily	
Lift System	Electrical operation	Operate lift system up and down several times electrically	<ul style="list-style-type: none"> • No excessive noise or extraneous sounds from lift motors • No rattles • Deck lifts and lowers within 3-4 seconds (each way) 		Daily	

Area	Description	Method of Inspection	Normal Condition	Findings Pass or Fail	Timing	Notes
Propulsion System	Electrical	Operate Fwd/Rev switch several times	<ul style="list-style-type: none"> Unit should run smoothly in either direction No rattling or excessive noise 		Daily	
General Inspection	Warning and branding labels are in good condition	Visual inspection	<ul style="list-style-type: none"> Labels are in place and not coming loose Labels are in good condition Red stripes are in place and in good condition 		Weekly	
Frame	Frame is in good condition <ul style="list-style-type: none"> No damage No excessive wear 	Visual inspection	<ul style="list-style-type: none"> Straight sections Smooth curves Flat surfaces Minor scratches and dings are expected 		Weekly	
Frame	Containment strap plate	Visual inspection	<ul style="list-style-type: none"> Plate should be flat and free of damage or excessive wear Plating should not be cracked or damaged Mounting screw should be tight 		Weekly	
Deck	Deck is in good condition <ul style="list-style-type: none"> No damage No excessive wear 	Visual inspection	<ul style="list-style-type: none"> Straight sections Smooth curves Flat surfaces Minor scratches and dings 		Weekly	
Deck	Yoke screws are not loose in deck	Manual inspection	Screws are tight		Weekly	
Brake System	No system leaks <ul style="list-style-type: none"> Fittings on master cylinder, connecting block & calipers Master cylinder body Caliper body Hoses 	Wipe around fittings and master cylinder with dry rag	No leaks (rag remains dry)		Weekly	
Brake System	Brake lever in good condition and operating properly	Visual inspection Operate brake	<ul style="list-style-type: none"> No visible damage Smooth operation 		Weekly	
Brake System	Mounting screws tight <ul style="list-style-type: none"> Master cylinder mount to handle Master cylinder cap Connecting block to base of enclosure Caliper mounting 	Manual inspection	<ul style="list-style-type: none"> Parts are tight to mounting surfaces 		Weekly	

Area	Description	Method of Inspection	Normal Condition	Findings Pass or Fail	Timing	Notes
Brake System	Mounting screws on brake discs are tight	Visual inspection	<ul style="list-style-type: none"> Mounting screws on brake disc are not backing out Brake disc is mounted tightly to the center wheel 		Weekly	
Brake System	Holding brake pawl in good condition and operating properly	Visual inspection Set brake	<ul style="list-style-type: none"> No visible damage Brake locks in place 		Daily	
Suspension	Wheels and tires are in good condition	Visual inspection	Wheels and tires are free of damage		Weekly	
Suspension	<p>Components are straight and undamaged</p> <ul style="list-style-type: none"> Front wheel mounting yoke Main axle Rear swivel caster frames 	Manual inspection	<ul style="list-style-type: none"> Components are not damaged and operate freely Main axle plating is not cracked or damaged 		Weekly	
Operator Interface	<p>External mounting screws are tight</p> <ul style="list-style-type: none"> Base plate mounting to frame Enclosure mounting or base plate Handle mounting screws Switch mounting hardware is tight 	Manual inspection	Components are tight to mounting surfaces		Weekly	
Operator Interface	<ul style="list-style-type: none"> Handle, enclosure and door are free of damage and in good condition Door latches are fully functional 	Visual inspection	<ul style="list-style-type: none"> Straight sections Smooth curves Flat surfaces Minor scratches and dings are expected 		Weekly	
Operator Interface	Handle grips	Visual inspection	Grips are not worn or damaged		Weekly	
Operator Interface	Containment strap	Manual / Visual inspection	<ul style="list-style-type: none"> Belt should be free of tears and abrasions Plating on buckle should not be cracked or damaged Mounting screws should be tight Mounting tab should not be bent or damaged Belt should retract into housing such that only the buckle protrudes Housing should not be cracked or damaged Strap tongue should rotate freely 		Weekly	

Area	Description	Method of Inspection	Normal Condition	Findings Pass or Fail	Timing	Notes
Electrical	Buttons and switches	Visual inspection	<ul style="list-style-type: none"> No cracks or damage. No loose mounting hardware. 		Daily	
Electrical	Lift system <ul style="list-style-type: none"> Limit switches Motor 	Manual inspection	<ul style="list-style-type: none"> No loose components Wiring harness are not damaged Check connectivity 		Every 2 weeks	
Electrical	Propulsion system <ul style="list-style-type: none"> Motor Clutch 	Manual inspection	<ul style="list-style-type: none"> No loose components Wiring harness are not damaged Check connectivity 		Monthly	
Brake System	Fluid level	Visual inspection	Fluid level up to notch in master cylinder reservoir		Monthly	
Brake System	Hose without damage, abrasion, wear	Visual inspection	No visible damage or wear		Monthly	
Brake System	Brake discs have minimal rub and warp	Spin wheel	Wheel should continue to rotate several times before stopping		Monthly	
Suspension	Wheels and casters spin freely	Manual inspection	Wheel should continue to rotate several times before stopping		Monthly	
Suspension	Mounting hardware is tight <ul style="list-style-type: none"> Front wheel yoke Rear caster frame Main axle mounts to frame and axle clamp Nuts for main wheels 	Manual inspection	All hardware is tight		Monthly	
Lift System	Lift system mount screws to frame and deck are tight	Manual inspection	Lift system mount screws are tight to frame; deck mounting screws are tight		Monthly	
Lift System	Hardware is properly installed and undamaged	Visual inspection	All hardware is in place and in good condition		Monthly	
Lift System	Acme screws	Visual inspection	<ul style="list-style-type: none"> Components move freely up and down the screws Screws are straight Screws are clear of debris 		Monthly	

Area	Description	Method of Inspection	Normal Condition	Findings Pass or Fail	Timing	Notes
Propulsion System	Propulsion system mount screws to frame and deck are tight	Manual inspection	Propulsion system mount screws are tight to frame		Monthly	
Propulsion System	Hardware is properly installed and undamaged	Visual inspection	All hardware is in place and in good condition		Monthly	
Propulsion System	<ul style="list-style-type: none"> Mounting hardware is properly installed and tightened Chain tension is within acceptable range 	Visual inspection	<ul style="list-style-type: none"> No loose or missing fasteners Approximately 1/4" play in chain when pushed between sprockets 		Monthly	
Operator Interface	Internal mounting hardware is tight	Manual inspection	Components are tight to mounting surfaces		Monthly	
Welds	Vertical slide mounting screws	Visual inspection	No cracks or damage		Monthly	
Welds	Guide block cotter pins in rod	Visual inspection	No cracks or damage		Monthly	
Welds	No cracked welds	Visual inspection	No cracks or damage		Monthly	
Welds	Front caster plate	Visual inspection	No cracks or damage		Monthly	
Welds	Base plate	Visual inspection	No cracks or damage		Monthly	
Welds	Enclosure	Visual inspection	No cracks or damage		Monthly	
Welds	Frame - general	Visual inspection	No cracks or damage		Monthly	
Welds	Handle cross bar	Visual inspection	No cracks or damage		Monthly	
Welds	Vertical slide rod	Visual inspection	<ul style="list-style-type: none"> Rod is straight with no signs of wear Rod plating is not cracked or damaged 		Quarterly	
Operator Interface	Guide blocks	<ul style="list-style-type: none"> Visual inspection Cycle deck up and down several times 	Blocks are not damaged or worn and move freely in the vertical slide		Quarterly	
Electrical	Wiring <ul style="list-style-type: none"> Wire connections Wire crimps, connectors and solder joints 	Manual inspection	No loose connections, crimps or solder joints		Quarterly	

Area	Description	Method of Inspection	Normal Condition	Findings Pass or Fail	Timing	Notes
Electrical	Control boards	Manual / Visual inspection	<ul style="list-style-type: none"> • No loose components • Wiring harness connectors are securely in place • Wiring harnesses are not damaged 		Quarterly	
Electrical	Operation	Cycle deck up and down several times	<ul style="list-style-type: none"> • Deck should move through entire range of motion without tripping circuit breaker • Buttons should not stick in down position 		Quarterly	



MAGLINE® INC.
Standish, Michigan 48658
1-800-MAGLINE (624-5463)
www.magliner.com

CoolLift® is a registered trademark owned by
Swift Water Logistics

Form # B9509
© Copyright 2020-2023, Magline, Inc.
REV 01/23