

HAND TRUCK SKID RUNNER INSTALLATION INSTRUCTIONS

Item	Description	Qty.	Part Number
Hand Truck Skid Runner Kit <i>includes items below</i>			3030161
1	LH skid runner	1	303018
2	RH skid runner	1	303019
3	Hex head bolt - 5/16"-18 x 1-1/4" long	2	80012
4	Locknut - 5/16"-18	2	80676
5	Pan head screw - 1/4"-20 x 1-7/8" long	2	80039*
	Pan head screw - 1/4"-20 x 2-1/4" long	2	80263**
6	Locknut - 1/4"-20	2	80675

TOOLS REQUIRED

- (1) #3 PHILLIPS SCREWDRIVER
- (1) 7/16" COMBINATION WRENCH OR SOCKET
- (1) 1/2" COMBINATION WRENCH OR SOCKET

*Basic handles (see below)

**Handle with U-brace or Hi-U extension (see below)

*Used for these handle models: 11, 3B, 3C, 14, 5A, 5C, 5E, 17, 18, 19, 2C, 24, 28, 30, 71, LB, LC

**Used for these handle models: 11, 18, 19 or 60 handles with Hi-U; 12, 22, GB, GD, 36 handles

- Assemble the skid runner to each side.
 - Align hole of skid runner (hole marked "A" for 10-inch wheels or "B" for 8-inch wheels) with hole in wheel bracket marked "C" (Figure 1).
 - Insert one 5/16"-18 hex head bolt through the back of wheel bracket and through skid runner. Secure with one 5/16" locknut (Figure 2). *Finger tighten nut for now.
 - Remove the lower handle mounting screw. Push skid runner towards the hand truck frame until upper mounting hole is opposite the frame/handle lower screw hole. Insert one 1/4"-20" pan head screw through side of the skid runner, frame side channel and handle. Secure with one 1/4"-20 locknut (Figure 3).
- Tighten bolts and screws used to fasten skid runner securely (50-60 inch lbs. torque for 1/4"-20 screws and to 120-140 inch lbs. for 5/16"-18 bolts).

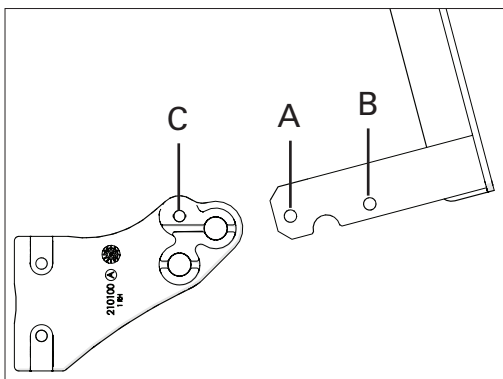

Figure 1

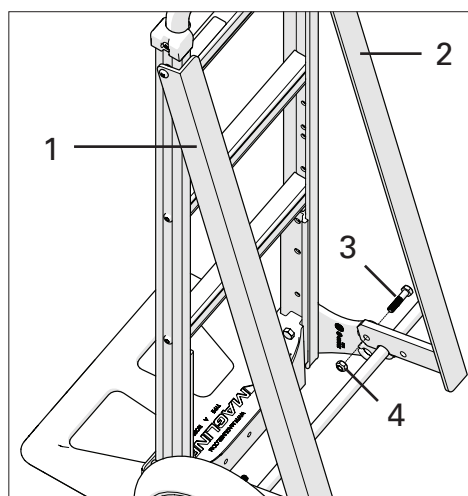

Figure 2

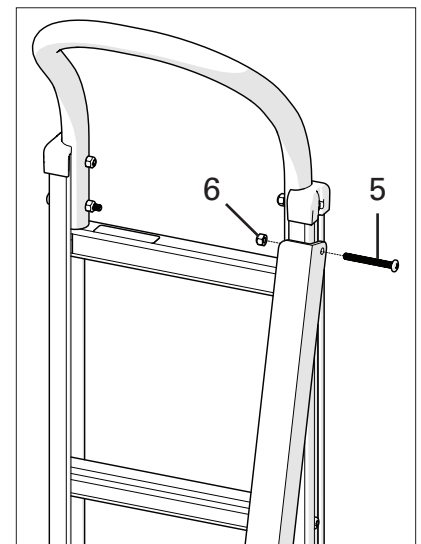

Figure 3