



**LiftPlus®**

# Maintenance Manual

Serial #: \_\_\_\_\_

Date of Purchase: \_\_\_\_\_



## Table of Contents

LiftPlus Toolkit.....	3
Safety Instructions.....	4
Removing Covers.....	5
Disconnecting/Connecting Battery.....	6
Lift Screw Girdle and Upper Belt.....	7
Replacing Lower Belt.....	7
Motor Assembly.....	8
Pulleys 1, 2-3.....	10
Motor and Solenoid Body.....	10
Motor Brake Pad.....	11
Lower Lift Screw Collar and Assembly.....	13
Pulley 4.....	13
Lift Screw Thrust Bearing.....	14
Lift Screw Guide.....	14
Trolley Assembly.....	16
Rear Rollers.....	16
Front Rollers.....	17
Caster Assembly.....	17
Disengaging/Engaging Brake Cable Ends.....	19
Brake Cable Assembly.....	19
Brake Caliper Assembly.....	19
Adjusting the Brakes, Caliper.....	20-21
Replacing Battery.....	22
Battery Box.....	22
Circuit Breaker.....	22
Lower Limit Switch.....	24
Upper Limit Switch.....	25
Power Switch; Up/Down Switch.....	26
Charging Light; Overload Light.....	26
Charging Input; Remote Control Input.....	27
Control Board Diagram.....	28-29
Maintenance.....	30
Troubleshooting Guide.....	31
Advanced Troubleshooting Guide.....	32-34
Replacement Parts List.....	54-56
Inspection / Maintenance Checklist.....	57-63

## LiftPlus Toolkit

- Standard Allen wrench set
- #1, #2 Phillips head screwdrivers
- Large flat head screwdriver
- Micro flat head screwdriver
- Standard socket wrench set
- Metric socket wrench set
- Standard combination wrench set
- Long handled magnetic driver with assorted Phillips and hex heads
- Crescent wrench
- Vise-grips
- Channel-lock pliers
- Dead blow hammer
- 1 lbs. hammer
- Needle Nose Pliers
- E-ring tool
- Pin punch set
- Wire stripper
- Wire cutter
- Wire crimper
- Cordless drill
- Drill bit set
- Blue thread locker
- Anti-static wrist strap

## Maintenance/Repair Safety Instructions

- Wear safety glasses when performing maintenance or repairs.
- Always use the correct tool type and size required for the job.
- Be careful not to cause cosmetic blemishes while working on the LiftPlus.
- Be careful not to strip or cross thread any fasteners especially in aluminum parts.
- Be careful not to damage any wire insulation.
- Engage the parking brake before working on the liftplus unless you will be working on the brake system.
- Do not Wear loose clothing, drawstrings, etc.
- Do not Use excessive force in any operation.
- Do not work on or around the drive or electrical components of the LiftPlus unless the power switch is off and the battery is disconnected.
- Do not activate the motor unless all hands and tools are clear of the drive system.
- Do not disconnect wire connectors by pulling on their wires. Grip only the connectors themselves.
- Do not contact the components of the control board with any metal tool.
- All replacements must be made with genuine Magliner parts.

## General Safety Instructions

- Inspect before each use for damaged and loose fasteners/connections.
- Inspect the unit for cracks, wear or damage. Replace damaged components immediately.
- Keep hands and feet away from all moving parts.
- Never stand or sit on the work bench.
- Do not use this product to lift or to transport people.
- Never use as a step ladder.
- Never use on a moving vehicle.
- Never operate when any of the housing components have been removed.
- Keep all loose items away from the lift screw, as they may become entangled during use.
- Never use or store in wet environments or get any of the unit wet. The unit may be used indoors or outside, but always use caution to keep the unit from getting wet; dry as soon as possible.
- Never exceed 350 lbs. capacity. Damage to the lift and personal injury could result.
- Never raise or lower the work bench unless the unit is unfolded and the folding latch is locked.
- Use extreme care when raising or lowering in close proximity to other objects. Hands and other items may get pinched or injured as the moving attachment passes non-moving objects.
- Never place a load's center of gravity over the vise or work bench nose; always keep the load center of gravity centered on the work bench.
- Never tilt the unit back with a raised load.
- Always check that the brakes are working correctly before operating with a load.
- Never walk away from the unit when the folding latch is in an unlocked position.
- Always keep the power switch off when the unit is folded.
- Never go over a curb or any other multi-level transition with a raised load.
- Do not operate when the battery charger is plugged in.
- Never attempt to open the battery. If the battery is cracked or leaking, do not recharge it - it must be replaced.
- Always use a Magliner battery charger to charge your battery.

# REMOVING COVERS

**TOOLS NEEDED:**

5/64" ALLEN WRENCH OR HEX DRIVER (BRAKE COVER)

7/64" ALLEN WRENCH OR HEX DRIVER (MOTOR COVER & TOP COVER)

**Brake Cover**

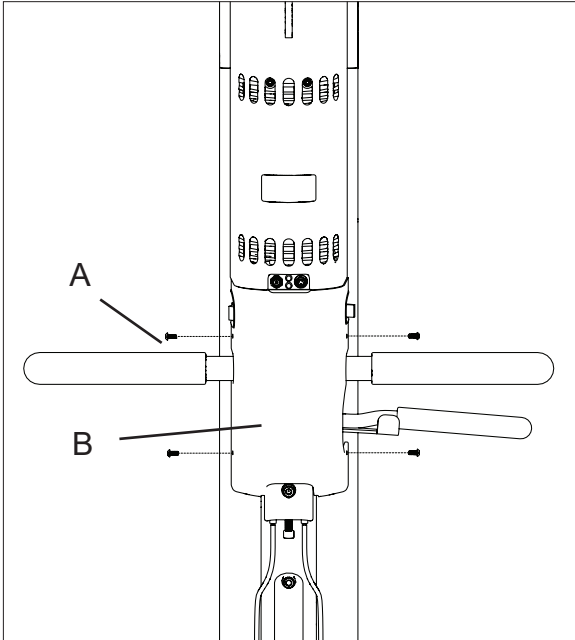

**Motor Cover/Top Cover**

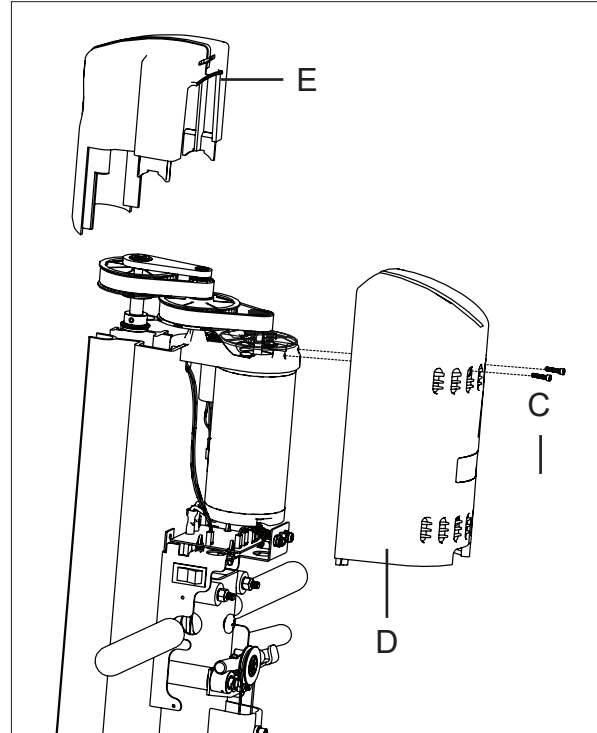

Note: when replacing the motor cover, move any protruding wires of the electrical assembly so they will be contained within the cover; make sure the bottom tabs slip under the protruding tabs of the electrical mount plate.

If the brake cover is installed, slide the motor cover down so that the bottom tabs slip inside the brake cover and under the protruding tabs of the electrical mount plate.

**Battery Cover**



Fold the LiftPlus; pull latch tab on top of the cover and slide down.

Item	Qty.	Part Number
A Button head cap screw - #6-32 x 5/16" long	4	80360
B Brake cover	1	533506
C Button head cap screw - #6-32 x 5/8" long	2	80359
D Motor cover	1	533505
E Top cover	1	533502
F Battery cover	1	533501

**DISCONNECTING/RECONNECTING BATTERY** (*disconnecting the battery is required for several processes in this manual*)

**TOOLS NEEDED: NONE**

1. Disconnecting the battery.
  - a. Fold the LiftPlus and remove battery cover.
  - b. Remove connectors off the positive and negative terminals.
  - c. Unfold and lock the LiftPlus.
2. Disconnecting the battery.
  - a. Fold the LiftPlus.
  - b. Slide the connectors onto the positive and negative terminals.
  - c. Install the battery cover; unfold and lock the LiftPlus.

**LIFT DRIVE SYSTEM**

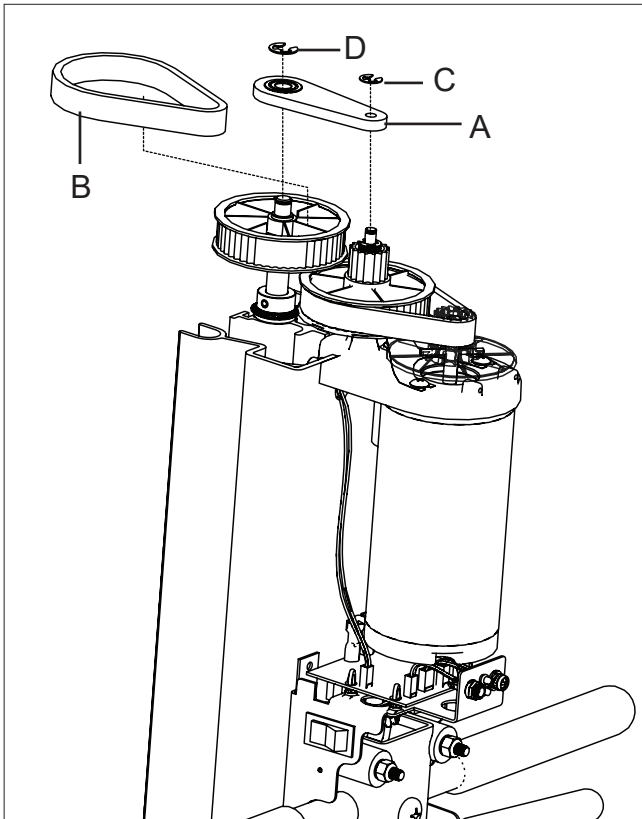

	Item	Qty.	Part Number
A	Lift screw girdle	1	531115
B	Belt	2	534118
C	E-ring for 1/4" dia. shaft	1	221011
D	E-ring for 3/8" dia. shaft	1	221012

**LIFT SCREW GIRDLE AND UPPER BELT**

**TOOLS NEEDED: NEEDLE-NOSED PLIERS OR E-RING TOOL; LARGE FLAT SCREWDRIVER; DEAD-BLOW HAMMER**

**Removal:**

1. Turn off the LiftPlus and disconnect the battery.
2. Remove motor and top covers.
3. Remove the E-rings from the top of the Pulley shaft and lift screw
4. Remove the lift screw girdle. If necessary insert a large flat blade screwdriver between the lift screw girdle and the top of either Pulley and gently twist.
5. Remove the upper belt by lifting it over the top of Pulley 2-3 while slowly turning Pulley 1 by hand.

**Installation:**

1. Turn off the LiftPlus and disconnect the battery.
2. Wrap the upper belt around Pulley 4 and stretch it just over the top of Pulley 2-3.
3. Press the belt down over Pulley 2-3 while turning Pulley 1 by hand.
4. Install the lift screw girdle, tapping gently with a dead-blow hammer if necessary.
5. Connect the battery unless other work on the lift drive system is planned.

**REPLACING LOWER BELT**

**TOOLS NEEDED: NONE**

**Removal:**

1. Turn off the LiftPlus and disconnect the battery.
2. Remove the lift screw girdle and upper belt.
3. Lift the Lower Belt over the top of Pulley 1 while slowly rotating Pulley 1.
4. Slide the lower belt out between Pulley 2-3 and Pulley 4

**Installation:**

1. Turn off the LiftPlus and disconnect the battery.
2. Slide the lower belt in between Pulley 2-3 and Pulley 4.
3. Wrap the lower belt around the bottom of Pulley 2-3 and stretch it just over the top of Pulley 1.
4. Press the belt down over Pulley 1, while hand turning Pulley 1.
5. Install the lift screw girdle and upper belt.
6. Connect the battery unless other work on the lift drive system is planned.

# LIFT DRIVE SYSTEM (CONT.)

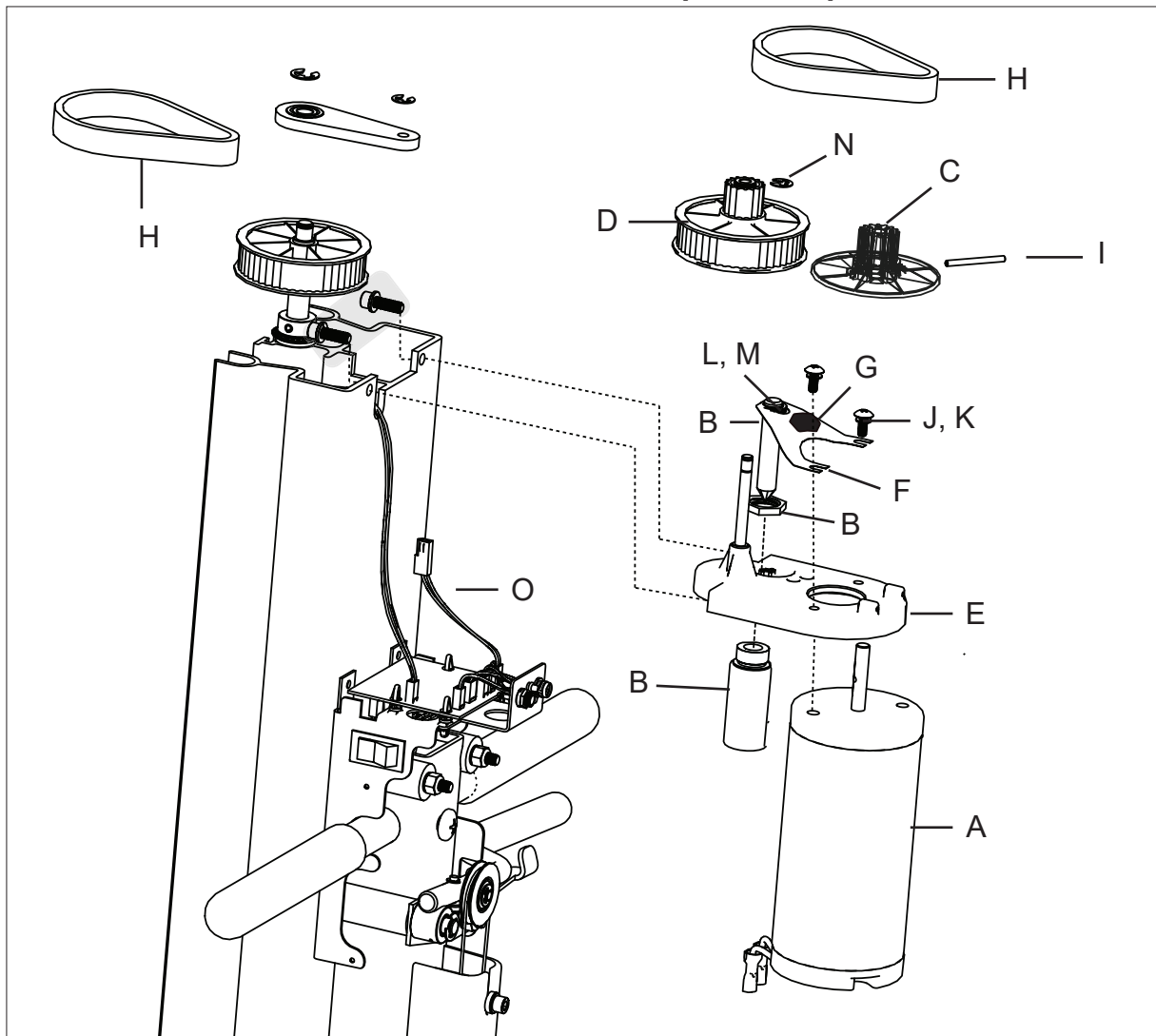

Item	Qty.	Part Number
<i>Complete motor assembly includes:</i>		
A	1	63024
B	1	63026
C	1	534106
D		534123
	1	534107
	2	534115
E	1	534102
F	1	534111
G	1	534112
H	2	534118
I	1	81166
J	2	80348
K	2	80767
L	3	80766
M	2	221014
N	2	221011

Motor Assembly Part No.:  
 48" models - 534100  
 60" models - 534100-60  
 72" models - 534100-72

*Complete motor assembly also includes:*

Item	Qty.	Part No.
O	1	534421
	1	534422
	1	534423



**MOTOR ASSEMBLY****TOOLS NEEDED: 3/16" MAGNETIC HEX DRIVER OR ALLEN WRENCH****Removal:**

1. Turn off the LiftPlus and disconnect the battery.
2. Remove lift screw girdle and upper belt.
3. Disconnect the motor and solenoid wires from rest of the electrical assembly by pulling apart the mating connectors. Do not pull on the wires themselves! If the connectors are difficult to separate try working them loose with gentle twisting and rocking.
4. Remove one of the motor mount screws with a 3/16" magnetic hex driver or Allen wrench.
5. Hold the motor with one hand and pull gently outward while unscrewing the remaining motor mount screw.

**Installation:**

1. Turn off the LiftPlus and disconnect the battery.
2. Hold the motor mount against the column ensuring that all wires needed to connect the motor and solenoid are accessible.
3. Be sure that the grommet to protect the upper limit switch wires is secure in its slot in the column. The motor mount traps this grommet in place.
4. Install the two motor mount screws (with lock washers) using a 3/16" magnetic hex driver or Allen wrench.
5. Connect the motor and solenoid wires to their mating wires.
6. Install the lift screw girdle and upper belt.
7. Connect the battery unless other work on the lift drive system is planned.

**Pulley 2-3 ASSEMBLY****TOOLS NEEDED: NEEDLE-NOSED PLIERS OR E-RING TOOL****Removal:**

1. Turn off the LiftPlus and disconnect the battery.
2. Remove the motor assembly.
3. Remove the .25" E-ring on the pulley post.
4. Slide the Pulley 2-3 assembly off the post.

**Installation:**

1. Turn off the LiftPlus and disconnect the battery.
2. Check to be sure that the pulley flanges are securely welded to the Pulley.
3. Slide the Pulley 2-3 assembly onto the pulley post.
4. Install the .25" E-ring onto the pulley post in the lower groove.
5. Install the motor assembly.

**Pulley 1 ASSEMBLY****TOOLS NEEDED: 1-2 lb. HAMMER; 1/8" PIN PUNCH**

**Note: excessive force can damage the Pulley or the Motor shaft. Be sure that you have the correct size punch and align and support everything carefully.**

**Removal:**

1. Turn off the LiftPlus and disconnect the battery.
2. Remove the motor assembly.
3. Place the motor assembly on a hard, flat, and stable surface with one of the long flat sides of the motor mount facing down.
4. Align Pulley 1 so that the split roll pin is vertical.
5. Using a 1/8" pin punch and a 1-2lb hammer drive the pin through until it clears the motor shaft.

6. Use careful steady blows, and:
  - a. Stop frequently to check the alignment of pin and punch.
  - b. Do not overdrive the pin
  - c. Be careful not to damage the pulley with a misaligned punch.

**Installation:**

1. Turn off the LiftPlus and disconnect the battery.
2. Slide the Pulley 1 onto the motor shaft.
3. Carefully align the holes in the motor shaft and Pulley 1 so that both are vertical.
4. Push a 1/8" by 1.5" long split roll pin into the top of the slot in Pulley 1.
5. Place the motor assembly on a hard, flat, and stable surface with one of the long flat sides of the motor mount facing down.
6. Using a 1-2lb-hammer deliver gentle blows to the pin until it enters the hole in the motor shaft.
7. Using a 1/8" pin punch and a 1-2lb hammer continue to drive the pin until it is fully engaged with the slot on Pulley 1.
  - a. Use careful, steady blows.
  - b. Stop frequently to check the alignment of pin and punch.
  - c. Do not over drive the pin.
  - d. Be careful not to damage the Pulley with a misaligned punch.
8. Install the motor assembly.

**MOTOR****TOOLS NEEDED: #2 OR #3 PHILLIPS SCREWDRIVER****Removal:**

1. Turn off the LiftPlus and disconnect the battery.
2. Remove the motor assembly.
3. Remove Pulley 1
4. Unscrew the screws holding the motor to the motor mount and remove the motor.
5. Slide the Pulley 2-3 assembly off the post.

**Installation:**

1. Turn power switch off and disconnect the battery.
2. Install the motor onto the motor mount, being careful to trap the motor brake lever under the lock washers.
3. Make sure that the washers are not deforming the motor brake lever and that the solenoid plunger and motor brake lever have free range of motion.
4. Install Pulley 1.
5. Install the motor assembly onto the LiftPlus

**SOLENOID BODY****TOOLS NEEDED: MINIATURE FLAT SCREWDRIVER, CHANNEL-LOCK PLIERS (optional), BLUE THREADLOCKER****Removal:**

1. Turn off the LiftPlus and disconnect the battery.
2. Remove the motor cover.
3. Remove the motor assembly.
4. Grip the solenoid body with a pair of channel-locks and twist it from right to left to loosen it.
5. Insert a small flat-blade screwdriver between the solenoid hex nut and the motor mount to prevent the nut from spinning.

6. Continue to turn the solenoid body by hand or with the channel-locks until it becomes free.
7. Remove the solenoid body and hex nut from the motor assembly.

**Installation:**

1. Turn power switch off and disconnect the battery.
2. Coat the threads of the solenoid body with blue thread locker.
3. Insert the solenoid body up through the hole in the motor mount.
4. Hand turn the hex nut onto the solenoid body as far as possible.
5. Insert a small flat-blade screwdriver between the solenoid hex nut and the motor mount to prevent the nut from spinning.
6. Turn the solenoid counterclockwise from the bottom until it is snug against the motor mount.
7. Connect the solenoid wires to the mating connector in the electrical assembly
8. Connect the battery unless other work on the lift drive system is planned.

**MOTOR BRAKE PAD*****TOOLS NEEDED: NEEDLE-NOSE VISE-GRIPS OR PLIERS*****Removal:**

1. Turn off the LiftPlus and disconnect the battery.
2. Remove the motor cover.
3. Grip the motor brake pad with a pair of needle nose vise-grips or pliers.
4. Hold the motor brake lever firmly against the motor mount with one hand.
5. Pull the motor brake pad straight upward until it pops free.

**Installation:**

1. Turn off the LiftPlus and disconnect the battery.
2. Insert the motor brake pad between the Pulley 1 and motor break lever so that the curve of the pad follows the curve of the pulley and the nipples of the pad protrude through the holes in the motor brake lever.
3. Using a small pair of needle nose vise-grips or pliers grasp the nipples and pull them down until they pop through the motor brake lever.
4. Install the motor cover.
5. Connect the battery unless other work on the lift drive system is planned.

## LIFT DRIVE SYSTEM (CONT.)

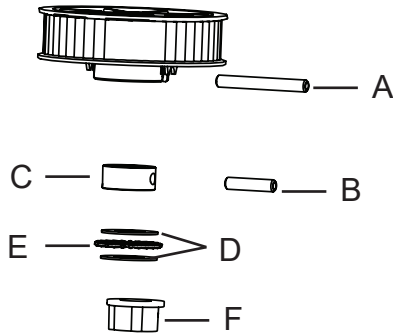

Item	Qty.	Part Number
Lift screw - 48"	1	531102
Lift screw - 60"	1	531105
Lift screw - 72"	1	531107

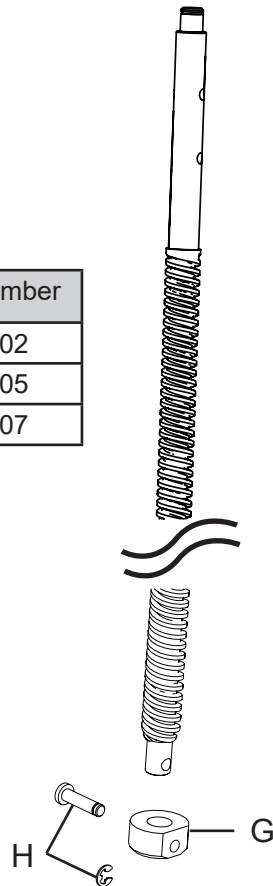

Item	Qty.	Part Number
A Spring pin - 3/16" dia. x 1-5/8" long	1	81167
B Spring pin - 3/16" dia. x 1" long	1	81168
C Upper lift screw collar	1	531113
D Thrust washer for 1/2" shaft	2	80796
E Lift screw thrust bearing	1	531114
F Guide bushing	1	80814
G Lower lift screw collar	1	531116
v Clevis pin with groove - 3/4" long (5/8" usable length) and E-ring	1	81165

**LOWER LIFT SCREW COLLAR****TOOLS NEEDED: NEEDLE-NOSE PLIERS OR E-RING TOOL****Removal:**

1. Drive the quick change latch to its lowest position.
2. Turn off the LiftPlus and fold the unit.
3. Remove the retaining ring on the clevis pin, then the clevis pin from the lower lift screw collar.
4. Slide the collar off of the lift screw.

**Installation:**

1. Slide the lower lift screw collar
2. Install the clevis pin and retaining ring.
3. Unfold and lock the LiftPlus.

**LOWER LIFT SCREW ASSEMBLY****TOOLS NEEDED: NONE****Removal:**

1. Remove the lower lift screw collar.
2. Disconnect the battery.
3. Unfold and lock the LiftPlus
4. Remove lift screw girdle and upper belt.
5. Hand-turn Pulley 4 counterclockwise until lift screw is free of trolley drive nut.
6. Pull lift screw assembly up and out of the column. It may be necessary to tap the bottom of the lift screw with a hammer to free the assembly from the column.

**Installation:**

1. Turn off the LiftPlus and disconnect the battery.
2. Slide the lift screw assembly down into the plastic guide in the column.
3. Hand turn Pulley 4 clockwise until the trolley begins to lift the platform.
4. Align the lift screw guide bushing with the opening at the top of the column and press it in. A dead-blow hammer may be used on the top of the lift screw, but be sure that the bushing is correctly aligned before every blow.
5. Install the lift screw girdle and upper belt.
6. Check to be sure that the guide has not slid out of the bottom of the column. If it has it must be slid back and held in place by hand to avoid damage while folding the LiftPlus.
7. Fold the LiftPlus
8. Install the lower lift screw collar.
9. Connect the battery unless other work on the lift drive system is planned.
10. Unfold and lock the LiftPlus.

**Pulley 4****TOOLS NEEDED: 1-2 LBS. HAMMER, 3/16" PIN PUNCH****Removal:**

1. Turn off the LiftPlus and disconnect the battery.
2. Slide Pulley 4 onto the lift screw.
3. Carefully align the holes in the lift screw and Pulley 4 so that both are vertical.
4. Push a 3/16" by 1.625" long split roll pin into the top of the slot in Pulley 4.
5. Place the lift screw assembly on a hard, flat, and stable surface with Pulley 4 protruding just past the edge.

&lt;OR&gt;

Place the lift screw assembly on the floor with a block supporting the lift screw just below Pulley 4.

6. Using a 1-2lb-hammer deliver gentle blows to the pin until it begins to enter the hole in the Lift screw.
7. Continue to drive the pin until the top of the pin is level with the edge of Pulley 4.
8. Drive the pin, using a 3/16" pin punch and a 1-2 lb hammer until it is fully engaged with the slot on Pulley 4.
  - a. Use careful steady blows.
  - b. Stop frequently to check the alignment of pin and punch.
  - c. Do not over drive the pin.
  - d. Be careful no to damage the Pulley with a misaligned punch.
9. Install the lift screw assembly onto the LiftPlus.

**LIFT SCREW THRUST BEARING****TOOLS NEEDED: 1-2 LBS. HAMMER, 3/16" PIN PUNCH****Removal:**

1. Turn off the LiftPlus and disconnect the battery.
2. Remove the lift screw assembly.
3. Remove Pulley 4.
4. Align the lift screw collar so that the split roll pin is vertical.
5. Using a 3/16" pin punch and a 1-2lb hammer drive the pin though until it clears the lift screw, but remains in the lift screw collar.
6. Use careful steady blows.
7. Stop frequently to check the alignment of pin and punch.
8. Slide the lift screw collar off of the lift screw.
9. Slide the lift screw thrust bearing and attending washers off of the lift screw.

**Installation:**

1. Turn off the LiftPlus and disconnect the battery.
2. Slide the lift screw thrust bearing sandwiched between the two lift screw thrust bearing washers onto of the lift screw.
3. Slide the lift screw collar with split roll pin partially installed onto the lift screw.
4. Carefully align the holes in the lift screw and lift screw collar so that both are vertical.
5. Push a 3/16" by 1.625" long split roll pin into the top of the slot in Pulley 4.
6. Using a 1-2 lb hammer deliver gentle blows to the pin until it begins to enter the hole in the Lift screw.
7. Continue to drive the pin until the top of the pin is level with the lift screw collar
8. Install Pulley 4 Install the lift screw assembly onto the LiftPlus.

**GUIDE****TOOLS NEEDED: NONE****Removal:**

1. Remove lift screw assembly.
2. Remove guide (it may be necessary to push the guide up from the bottom until it can be grasped and pulled out the top).

**Installation:**

1. Slide guide into column.
2. Install the lift screw assembly.

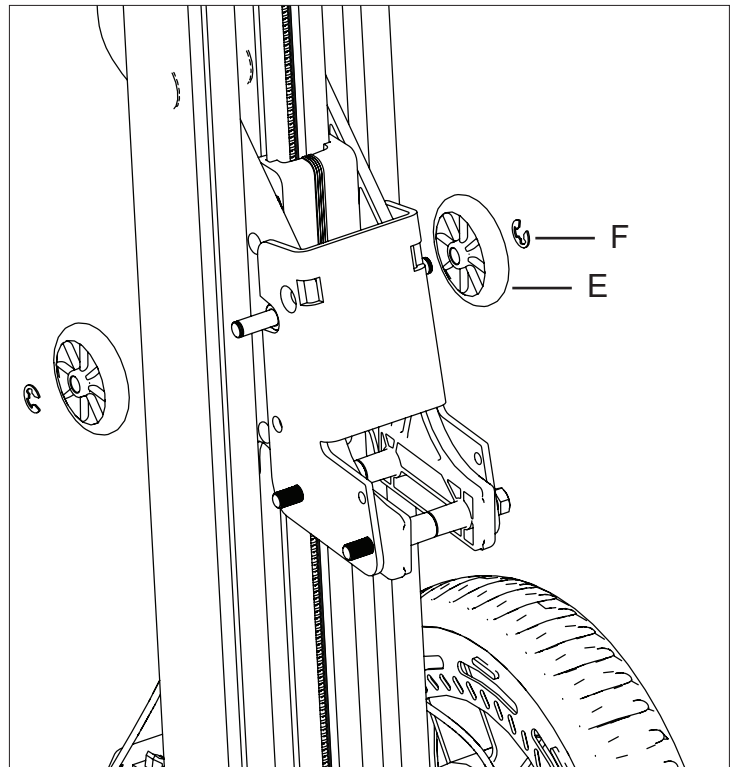
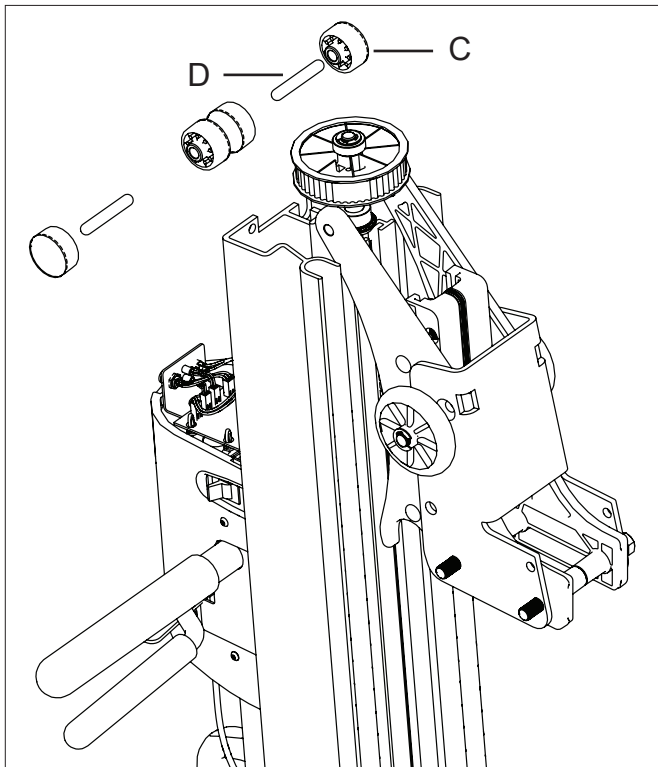
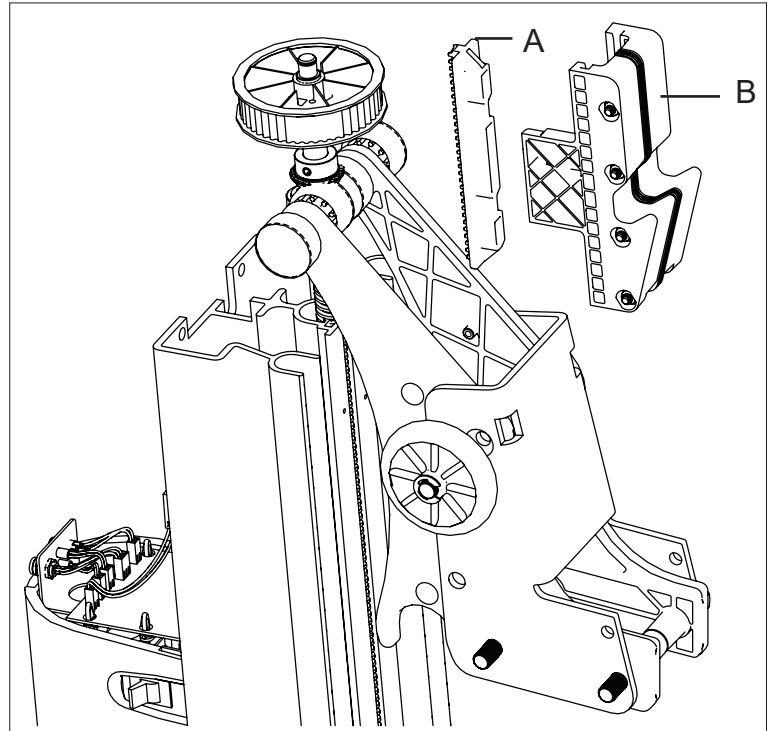
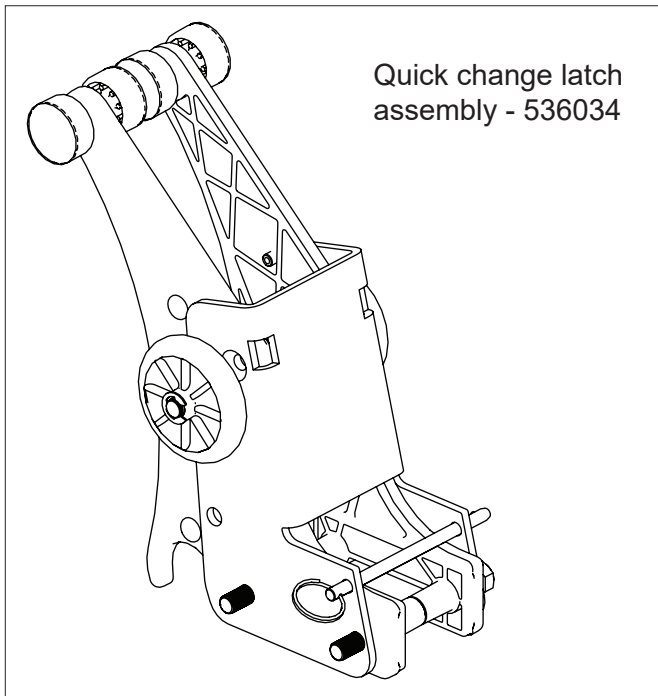

Item	Qty.	Part Number
A	1	531705
B	1	531700
C	4	531709
D	2	22146
E	2	531708
F	2	221012

**TROLLEY ASSEMBLY****TOOLS NEEDED: #1 PHILLIPS SCREWDRIVER****Removal:**

1. Drive the trolley up to the upper limit switch.
2. Engage the parking brake; fold the LiftPlus.
3. Turn power switch off and disconnect the battery.
4. Remove the lower lift screw collar.
5. Remove lift screw girdle and upper belt.
6. Using a #1 Phillips driver remove upper limit switch leaving it connected to the wires.
7. Pull lift screw assembly up until trolley becomes free and remove the trolley and trolley drive nut
8. Gently slide the lift screw back to rest.

**Installation:**

1. Pull the lift screw out until at least 9" of thread are exposed
2. Press trolley assembly against it so that the trolley drive nut engages the threads of the lift screw
3. Slide the lift screw back down into the column so that the trolley and drive nut slide back into their track.
4. Align the lift screw guide bushing with the opening at the top of the column and press it in. (A dead-blow hammer may be used on the top of the lift screw, but be sure that the bushing is correctly aligned before every blow.
5. Install the lift screw girdle and upper belt.
6. Hand turn pulley 4 counter-clockwise until the trolley clears the upper limit switch mounting area.
7. Replace the upper limit switch, checking that connections are secure, sleeving is in place and wires are undamaged.
8. Check to be sure that the guide has not slid out of the bottom of the column. If it has it must be slid back and held in place by hand to avoid damage while folding the LiftPlus.
9. Fold the LiftPlus
10. Install the lower lift screw collar.
11. Connect the battery.
12. Partially unfold the LiftPlus until it is 15-20° from vertical.
13. Turn on power; drive the trolley down to the lower limit switch.
14. Fully unfold and lock the LiftPlus.

**REAR ROLLERS****TOOLS NEEDED: NONE****Removal:**

1. Remove the top cover and upper limit switch.
2. Remove the motor assembly.
3. Slide the quick change latch up until the rear rollers clear the top of the column.
4. Slide the outer rear rollers off of the rear roller axles.
5. Slide one of the rear roller axles out of the side plate.
6. Remove the inner rear rollers and quick change latch.

**Installation:**

1. Remove all rear rollers and one rear roller axle from the platform assembly.
2. Hold the platform assembly at the top of the column with the top of the side plates straddling the lift screw below the Pulley 4.
3. Install the rear rollers onto the installed rear roller axle.
4. Hold the remaining inner rear roller in place the remaining rear roller axle through the side plate and into the roller.
5. Install the last rear roller.
6. Slide the rear rollers into the column and lower the quick change latch.
7. Install the motor assembly and the upper limit switch. Install the top cover.



**FRONT ROLLERS**

**TOOLS NEEDED: NEEDLE-NOSE PLIERS OR E-RING TOOL**

**Removal:**

1. Rotate the quick change latch upward to expose the front rollers.
2. Remove the e-ring that retains the front roller.
3. Remove the front roller from the front axle.

**Installation:**

1. Slide the front roller onto the front axle.
2. Install the .375" E-ring onto the front axle.

**CASTER ASSEMBLY**

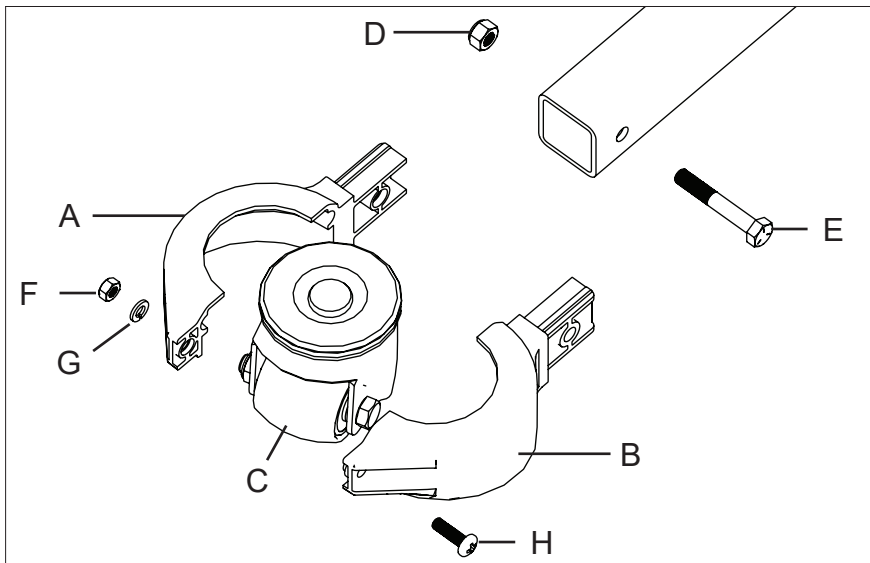

Top "lip" of the caster shells fit within this groove for assembly.

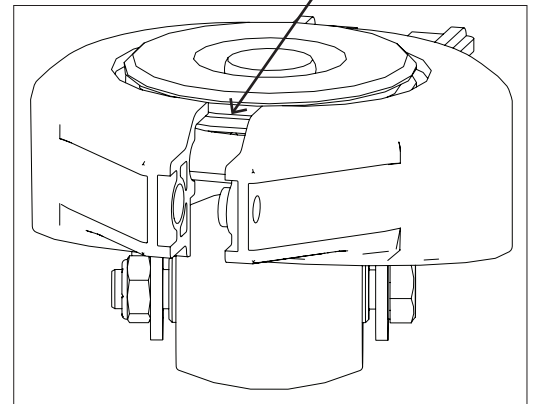

	Item	Qty.	Part Number
A	Caster shell - RH	1	532504
B	Caster shell - LH	1	532503
C	Caster assembly with plate	1	532500
D	Lock nut with nylon insert - 5/6"-24	1	80606
E	Screw - 5/16"-24 x 2" long	1	80346
F	Lock nut - M6	1	80612
G	Split lock washer - M6	1	80794
H	Screw - M6 x 20mm long	1	80362

Quantities listed are for one arm of the LiftPlus.

**TOOLS NEEDED: 1/2" WRENCHES; PHILLIPS SCREWDRIVER; 10M SOCKET WRENCH**

**Removal:**

1. Remove screw and lock nut to remove caster assembly from the LiftPlus arm.
2. Remove the screw, lock nut and washer from the caster shells to release the caster from the shells.

**Installation:**

1. Slide the caster shells around the caster plate as shown. Slide the M10 screw through both shells and secure with the washer and lock nut.
2. Slide the caster shells into the LiftPlus arm and secure with 2" long screw and lock nut.

# BRAKE SYSTEM

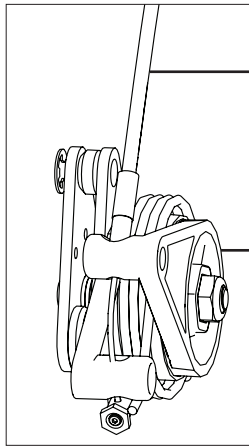

Cable assembly (must specify 14" or 25" chassis upon order)

A, B

	Item	Qty.	Part Number
A	Brake caliper, RH	1	532100R
B	Brake caliper, LH	1	532100L

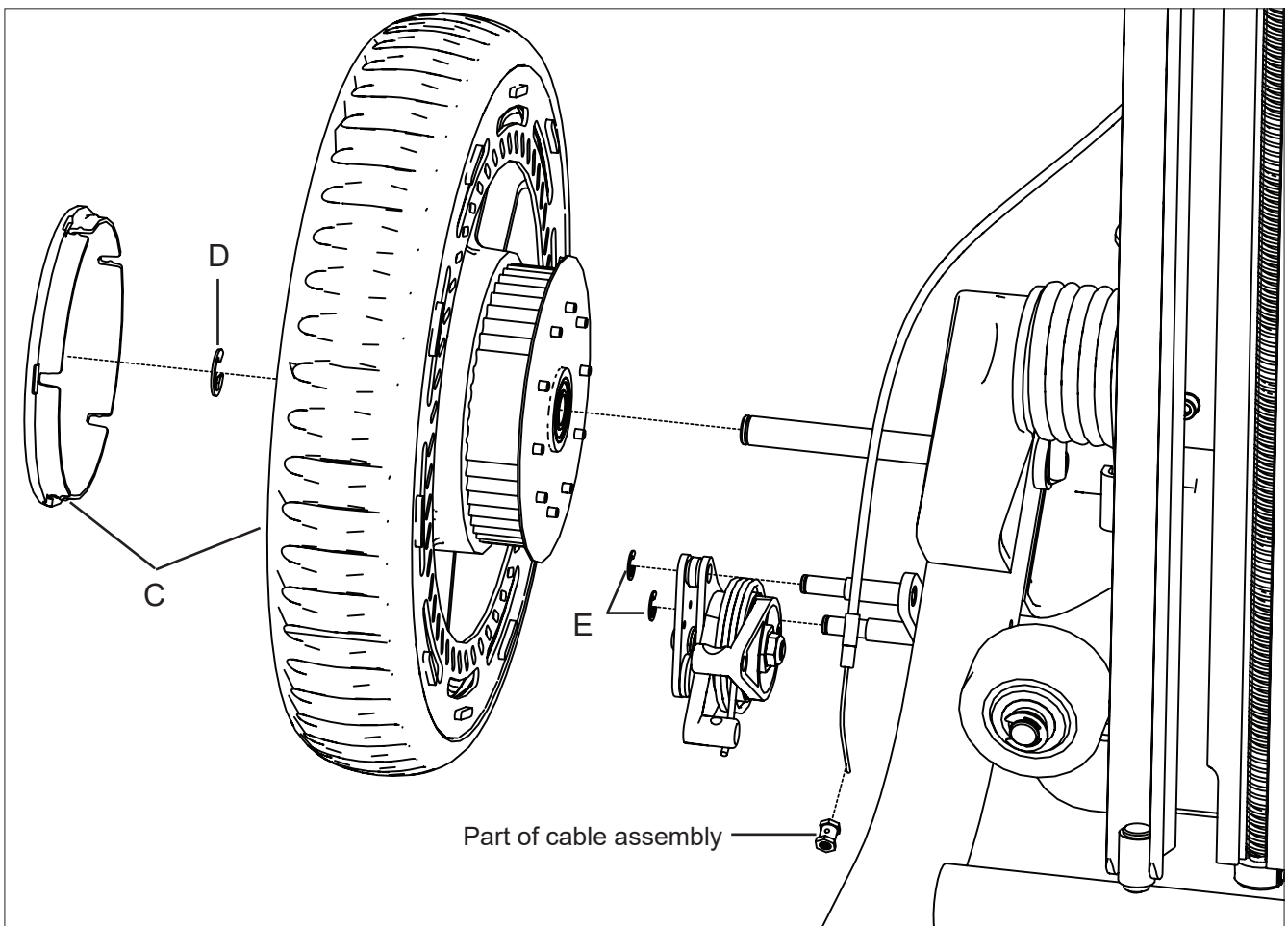

	Item	Qty.	Part Number
C	Wheel assembly	1	532310
D	E-ring - 1/2"	1	221009
E	E-ring - 5/16"	2	221010

Quantities listed are per side of the LiftPlus.

**DISENGAGING/ENGAGING THE BRAKE CABLE ENDS****TOOLS NEEDED: VISE-GRIPS****Disengage:**

1. Grip the adjustable cable crimps with a pair of vise-grips.
2. Loosen the setscrew using a hex driver or allen wrench.
3. Remove the adjustable cable crimps from the cable
4. Pull the cable through the holes in the brake arms.

**Engage:**

1. Remove the brake cover.
2. Pass the cable ends through the holes in the brake arms.
3. Install an adjustable cable crimp 2" from one end of the cable and secure it with a hex driver or allen wrench.
4. Squeeze both sets of brake arms and pull the free end of the cable taught, gripping it with a pair of vise-grips.
5. Install an adjustable cable crimp securely on the cable as close to the cable arm as possible.

**BRAKE CABLE ASSEMBLY****TOOLS NEEDED: WIRE CUTTERS, 3/16" HEX DRIVER OR ALLEN WRENCH****Removal:**

1. Remove the brake cover.
2. Disengage both ends of brake cable.
3. Cut the brake cable ties.
4. Loosen the cable mount retaining screw using a 3/16" hex driver or Allen wrench.
5. Remove cable mount.
6. Remove the brake cable assembly.

**Installation:**

1. Turn the brake adjustment screw counter clockwise until it no longer protrudes through the brake cable mount.
2. Slide the ferrules on middle ends of the cable housings into the holes on the bottom of the cable mount.
3. Place the cable mount against the bayonet and slide it under the retaining screw so that both washers are on top of the cable mount.
4. Loop the middle of the cable over the brake balance pulley.
5. Tighten the cable mount retaining screw using a 3/16" hex driver or Allen wrench.
6. Engage the both cable ends with the brake arms.
7. Install new brake cable ties so that they pass between the column and bayonet and around each cable housing. Install one 4-5" above the battery compartment and one level with the middle of the column handle.
8. Perform a brake adjustment.
9. Install the brake cover.

**BRAKE CALIPER ASSEMBLY****TOOLS NEEDED: WIRE CUTTERS, 3/16" HEX DRIVER OR ALLEN WRENCH****Removal:**

1. Disengage both ends of brake cable from the brake arms.
2. Disengage the brake arm springs from the brake arms and remove them.
3. Loosen the screw in the brake caliper assembly using a 3/16" hex driver or Allen wrench until it is free of the nut in the inner brake arm.
4. Pull the screw out and catch the brake arms, brake ball keeper, and brake balls as they become free.
5. Remove the hubcap using a large flat-blade screwdriver.
6. Remove the e-rings from the axle and the brake pad mounts.
7. Place blocking under the chassis on the side you are working.
8. Slide off the outer brake pad.

9. Slide the rear wheel assembly off the axle.
10. Slide the inner brake pad and brake pad spacers off the mounts.

**Installation:**

1. Place blocking under the chassis on the side you are working.
2. Slide the inner brake pad and brake pad spacers onto the mounts.
3. Slide the rear wheel assembly onto the axle.
4. Slide on the outer brake pad.
5. Install the 1/2" e-ring onto the axle and the 5/16" e-rings onto the brake pad mounts.
6. Inspect replaced e-rings for secure fit. Replace any that are loose.
7. Install the hubcap.
8. Assemble the brake arms, brake ball keeper, and brake balls and hold them inside the inner brake pad so the center holes of all pieces line up and the pin in the outer brake arm fits into one of the small holes in the inner brake pad.
9. Slide the .3125"-18 X 1.75" long Allen button head screw through from the outer brake pad to the inner brake arm.
10. Tighten the screw into the brake caliper assembly using a 3/16" hex driver or Allen wrench until clamps the brake pads on the brake rotor.
11. Back the screw off 1/2 turn.
12. Install the brake arm spring and engage it with the brake arms.
13. Engage both ends of the brake cable with the brake arms.
14. Perform brake adjustment procedures until brakes function properly.

## **Adjusting the Brakes**

The brakes are adjusted at the factory, but should still be checked before every use. If the braking power is insufficient, the brakes should be adjusted. Perform the adjustment on a dry, non-slippery surface.

There are two forms of adjustment. One adjusts the brake cable tension and the other adjusts the set of brake calipers. Adjusting the brake cable tension is usually sufficient. If you are unable to achieve sufficient braking force by tightening the cable or if one wheel brakes more effectively than the other, you may need to adjust the brake caliper.

### **Adjusting the Brake Cable Tension**

1. Loosen the screw (1) that locks the brake cable mount using a 3/16" Allen wrench.
2. Adjust the tension in the cables by turning the brake adjustment screw (2) that protrudes from the bottom of the brake cable mount using a 3/16" Allen wrench.
3. After adjusting the brake adjustment screw, re-tighten the locking screw.
4. To test the tension, squeeze the brake lever tightly, tilt the unit back about 35°, and push the unit forward along the ground. The combined action should make the wheels skid on the ground.
5. If the wheels spin, the brakes are not adjusted correctly. If the cable is too tight, it may engage the brakes when you are not pulling on the brake lever.

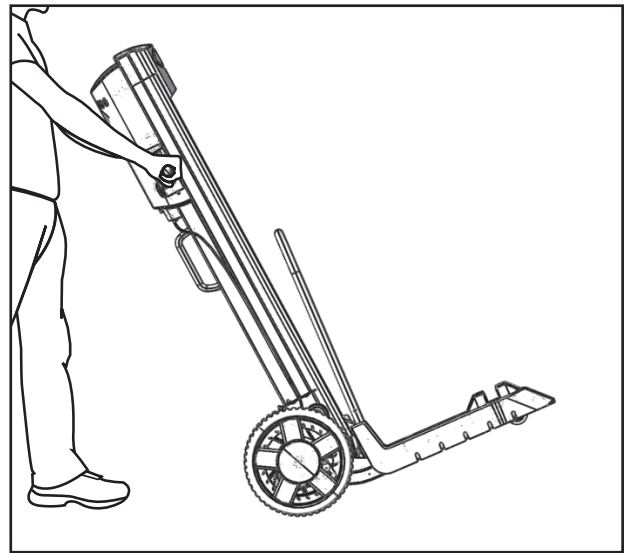
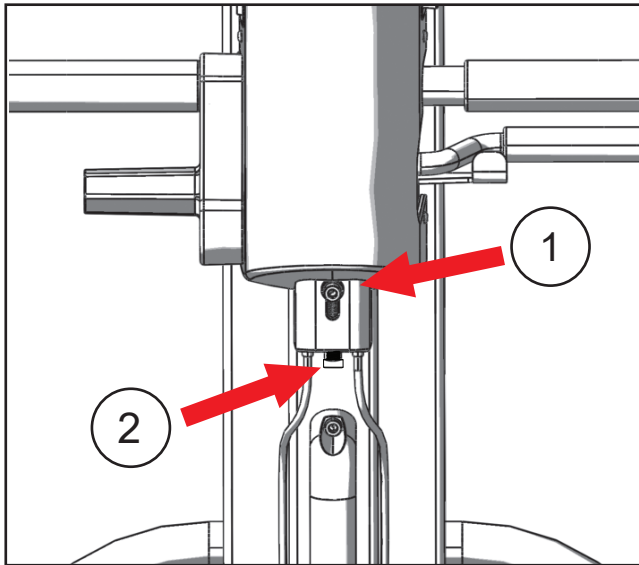

### Adjusting the Brake Calipers

The brake calipers can be adjusted using a 3/16" hex screwdriver. The brake caliper screws are accessed between the wheel spokes on either side.

1. Adjust the brake cable mount to its highest position as described in the preceding section (Adjusting the Brake Cable Tension).
2. Turn the brake caliper screw clockwise as far as it will go without excessive force.
3. Back both screws off one half turn in the opposite direction.
4. To test the caliper adjustment, push the unit around while not engaging the brakes. If you feel that either brake is dragging too much, try backing out the screw another 1/8 of a turn at a time until the unit rolls freely. **Note:** It is normal for the brakes to rub slightly, but they should not drag enough to interfere with easy rolling of the unit.
5. Perform the full brake cable tension adjustment as described in the previous section.

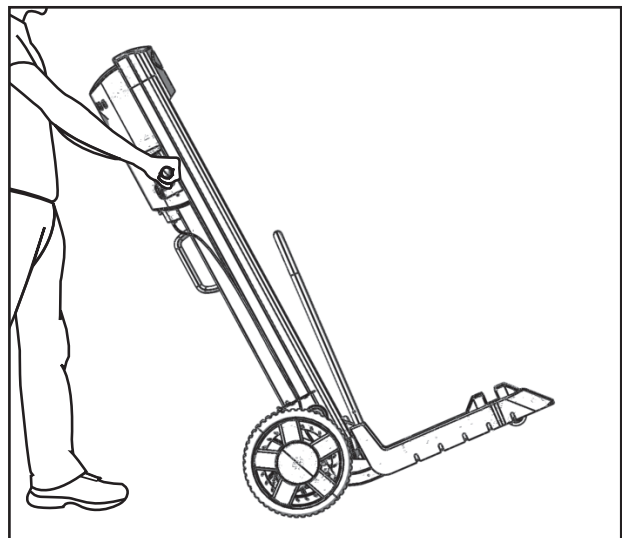
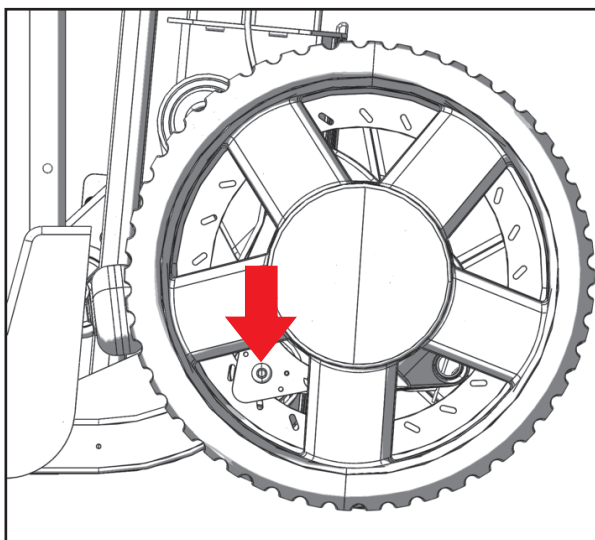

# ELECTRICAL SYSTEM

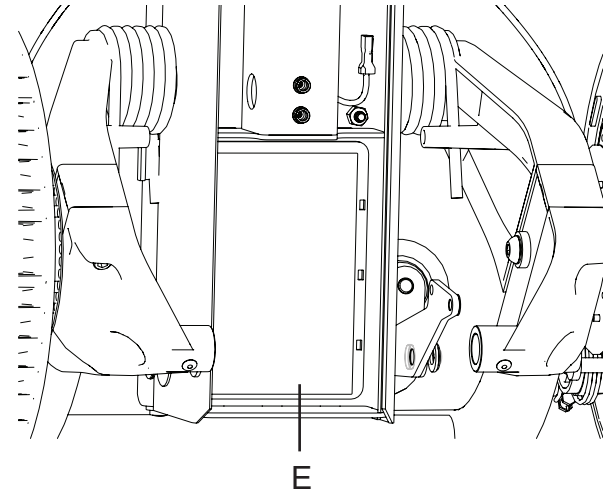
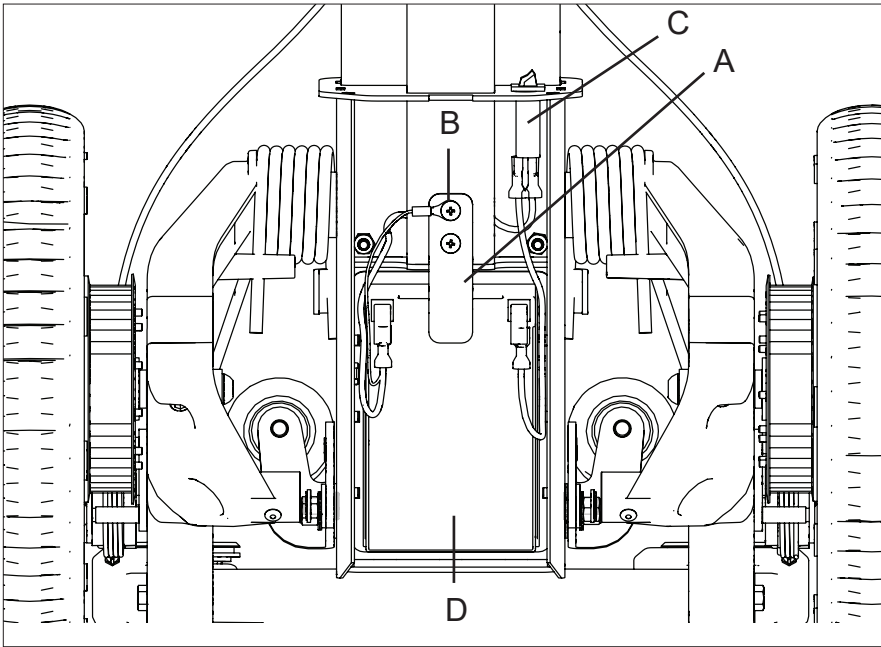

	Item	Qty.	Part Number
A	Battery bracket	1	530520
B	Truss head Phillips machine screw - #10-32 x .500" long	2	80348
C	Circuit breaker w/wiring harness - 15A, 32 VDC, 250 VAC	1	534415
D	Battery - 12V-15.0 Ah	1	61017
E	Battery box	1	533500

## BATTERY

**TOOLS NEEDED: #2 OR #3 PHILLIPS SCREWDRIVER**

### Removal:

1. Turn off the LiftPlus; fold and lock into place.
2. Remove the battery cover.
3. Slide the connectors off the positive and negative terminals.
4. Remove the battery bracket using a Phillips driver.
5. Inspect the Battery for cracks, leaks, and corrosion. **If you find cracks, leakage or corrosion on the battery:**
  - a. Contact Customer Service to order a replacement battery - do not operate the LiftPlus until repairs are made.
  - b. Wear acid-resistant gloves and chemical goggles. Do not let leakage contact your skin.
  - c. If leakage gets onto the skin, flush immediately with water and mild soap. If irritation develops, seek medical attention. If the leakage gets into the eyes, flush with clean water for 15 minutes and seek immediate medical attention.
4. Remove the battery.

### Installation:

1. Place battery in battery box.
2. Connect the red wire to the positive terminal and the black wire to the negative terminal.
3. Install the battery bracket using two 10-32 x .500" long screws with lock washers.
4. Be sure to connect the grounding wire ring terminal around on of the battery bracket screws.
5. Install the battery cover; unfold and lock the LiftPlus.

**CIRCUIT BREAKER****TOOLS NEEDED: WIRE CUTTERS (removal only)****Removal:**

1. Turn off the LiftPlus.
2. Fold the LiftPlus.
3. Remove the battery cover and disconnect the battery.
4. Slide the wire connectors off of the circuit breaker terminals.
5. Clip the circuit breaker retaining ring with a pair of wire cutters.
6. Remove the circuit breaker.

**Installation:**

1. Push the circuit breaker through the hole in the top of the battery compartment.
2. Be sure that the bezel of the circuit breaker is flush with the top of the battery compartment. You may need to reorient it in the hole.
3. Place a new retaining ring loosely around the circuit breaker.
4. Slide the wire connectors onto the circuit breaker terminals in any order.
5. Slide the retaining ring up until the circuit
6. Breaker is secure.
7. Reconnect the battery unless further work on the electrical system is planned.

**BATTERY BOX****TOOLS NEEDED: LARGE FLAT SCREWDRIVER****Removal:**

1. Turn off the LiftPlus and remove the battery
2. Remove the battery box by pushing up from below. It may be necessary to pry at the upper lip with a large flat-blade screwdriver.

**Installation:**

1. Push battery box into place, being certain that the slots cut into one of the underside edges are facing toward the top of the LiftPlus.
2. Install the battery.



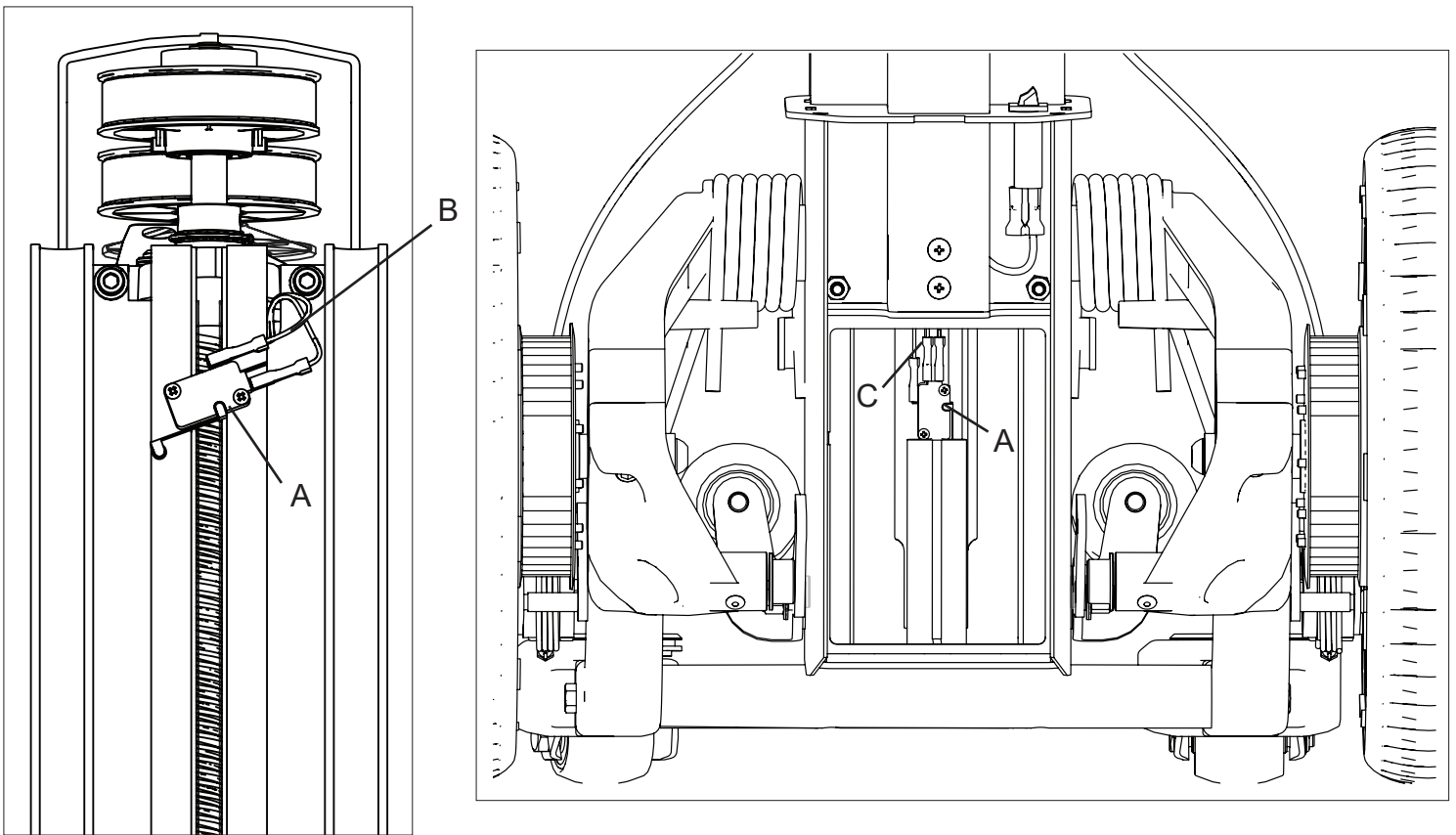

	Item	Qty.	Part Number
A	Limit switch (upper and lower)	2	62067
Wiring harness for upper limit switch:			
B	48" models	1	534401
	60" models	1	534405
	72" models	1	534406
C	Wiring harness for lower limit switch	1	534402

**LOWER LIMIT SWITCH**

**TOOLS NEEDED: #1 PHILLIPS SCREWDRIVER, BLUE THREAD LOCKER**

**Removal:**

1. Turn power switch off and remove the battery.
2. Remove the battery box.
3. Remove the screws fastening the lower limit switch using a #1 Phillips driver.
4. Slide the wire connectors off of the lower limit switch terminals.

**Installation:**

1. Slide the Blue wire connector onto the Lower Limit Switch terminal labeled "NO".
2. Slide the Orange wire connector onto the Lower Limit Switch terminal labeled "Com".
3. Slide the orange with white stripe wire connector onto the lower limit switch terminal labeled "NC".
4. Coat the threads of two #4-40 X .5" long Phillips machine screws with blue thread locker.
5. Place the lower limit switch against the column so that the roller on the switch lever is to the right and below the rest of the switch.
6. Fasten the lower limit switch to the column using the two screws. NOTE: Do not over tighten the screws.
7. Install the battery box and the battery.
8. Unfold and lock the LiftPlus.



**UPPER LIMIT SWITCH**

**TOOLS NEEDED: #1 PHILLIPS SCREWDRIVER, BLUE THREAD LOCKER**

**Removal:**

1. Turn power switch off and remove the battery.
2. Remove the top cover.
3. Remove the screws fastening the upper limit switch using a #1 Phillips driver.
4. Slide the wire connectors off of the upper limit switch terminals.

**Installation:**

1. Slide the purple wire connectors onto the upper limit switch terminals labeled “Com” and “NC”.
2. Coat the threads of the #4-40 X .5” long machine screws with thread locker.
3. Place the upper limit switch against the top of the column so that the holes line up and the roller on the switch is the lowest part.
4. Fasten the upper limit switch to the column using the two screws. NOTE: Do not over-tighten the screws.
5. Install the top cover.

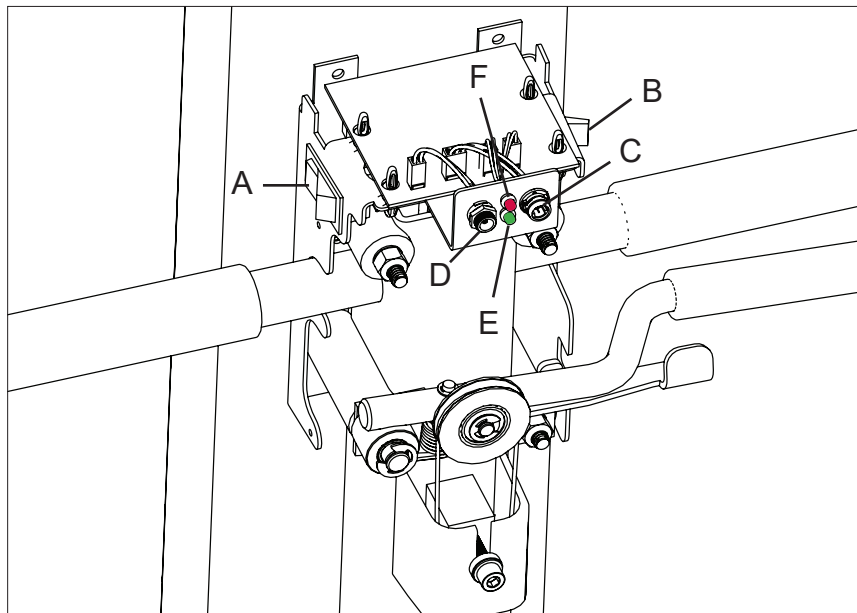

Item	Qty.	Part Number
A On/Off switch (includes wiring harness)	1	534410
B Up/Down switch (includes wiring harness)	1	534416
C Wiring harness/connector for remote control input	1	534409
D Wiring harness/connector for charger input	1	534408
E Wiring harness for green charging light	1	534411
F Wiring harness for red overload light	1	534412

**POWER SWITCH****TOOLS NEEDED: LARGE FLAT SCREWDRIVER (removal only)****Removal:**

1. Turn power switch off and disconnect the battery, leaving the LiftPlus folded.
2. Remove the brake cover.
3. Reach one finger around the wires connecting to the power switch and pull them gently toward you.
4. Press down and outward on the top of the power switch with a large flat blade screwdriver.
5. Do this several times until locking tabs on the power switch clear the edge of the electrical mount plate.
6. Pull the power switch out of the electrical mount plate.
7. Slide the wire connectors off of the power switch terminals.

**Installation:**

1. Push the power switch into the hole in the electrical mount plate until it is flush with the plate.
2. Install the brake cover.
3. Reconnect the battery unless further work on the electrical system is planned.

**UP-DOWN SWITCH****TOOLS NEEDED: LARGE FLAT SCREWDRIVER****Removal:**

1. Turn power switch off and disconnect the battery leaving the LiftPlus folded.
2. Remove the brake cover.
3. Grasp the switch with one hand and pull gently outward while pressing down and outward on the top of the up-down switch with a large flat blade screwdriver. There are two small metal tabs that dig into the metal of the electrical mount plate. Pressing directly on these tabs will help to move the switch.
4. Do this several times until the up-down switch can be pulled and rocked free.

**Installation:**

1. Orient the up-down switch so that the orange wire is facing up toward the user.
2. Push the up-down switch into the hole in the electrical mount plate until it is flush with the plate.
3. Install the brake cover.
4. Reconnect the battery unless further work on the electrical system is planned.

**RED AND GREEN LIGHTS WITH WIRING HARNESS****TOOLS NEEDED: NONE****Removal:**

1. Turn power switch off and disconnect the battery leaving the LiftPlus folded.
2. Remove the brake cover. Unplug the red or green light wiring harness from the control board.
3. Remove wiring harness by pulling out from the back of the electric mount plate.

**Installation:**

1. Push the wiring harness through the electrical mount plate from back to front. Make sure that the light's outer rubber seal is evenly seated between the bulb and the electrical mount plate.
2. Plug the wiring harness into the control board (see page 29 for reference).

## POWER JACK (CHARGER INPUT) AND WIRING HARNESS

**TOOLS NEEDED: 10M SOCKET WRENCH**

### Removal:

1. Turn power switch off and disconnect the battery leaving the LiftPlus folded.
2. Remove the brake cover. Unplug the power jack wiring harness from the control board.
3. Remove the lock nut from the front side of the power jack connector.
4. Remove the harness from the LiftPlus by pulling through the back of the electrical mount plate.

### Installation:

1. Remove the lock nut from the new harness.
2. Push the wiring harness through the electrical mount plate from back to front.
3. Slide the lock nut onto the connect from the front of the electrical mount plate; tighten the lock nut firmly against the electrical mount plate.
4. Plug the wire connector into the control board (see page 29 for reference).

## REMOTE CONTROL INPUT AND WIRING HARNESS

**TOOLS NEEDED: 10M SOCKET WRENCH**

### Removal:

1. Turn power switch off and disconnect the battery leaving the LiftPlus folded.
2. Remove the brake cover. Unplug the remote input wiring harness from the control board.
3. Remove the white wire connector from the wiring harness. Remove the metal washer and lock nut from the back side of the remote control connector.
4. Remove the harness from the LiftPlus by pulling through the front of the electrical mount plate.

### Installation:

1. Remove the metal washer and lock nut from the new harness.
2. Push the wiring harness through the electrical mount plate from front to back; orient the remote control connector so that the arrow is pointing Up.
3. Slide the washer and locknut onto the wiring harness; tighten the lock nut firmly against the electrical mount plate.
4. Push the wires fully into the white wire connector in the order shown below.
5. Plug the wire connector into the control board (see page 29 for reference).

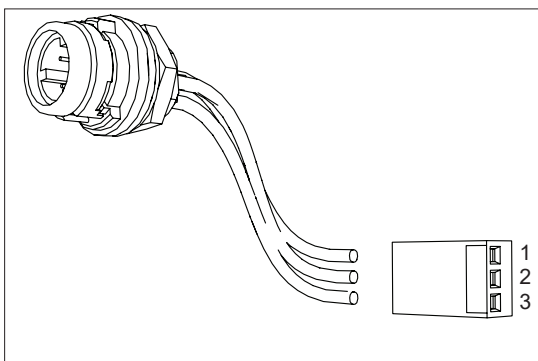

Pin No.	Color
1	Orange
2	Purple
3	Red

### Control Board Diagram

**Caution:** Disconnect the battery before making any replacements to the wiring harnesses or control board.

When connecting wire terminals, make sure the locking tabs on all wires and the board are facing each other.

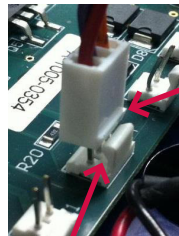

Locking tab on wiring harness

Locking tab on control board

### Control Board Diagram - Bottom

Orient the bottom of the board to the exposed wires that come through the board's mount place; connect all terminals as shown. Once all connections are secured align the four white locking pins on the plate mount to the four holes on the board to secure the board.

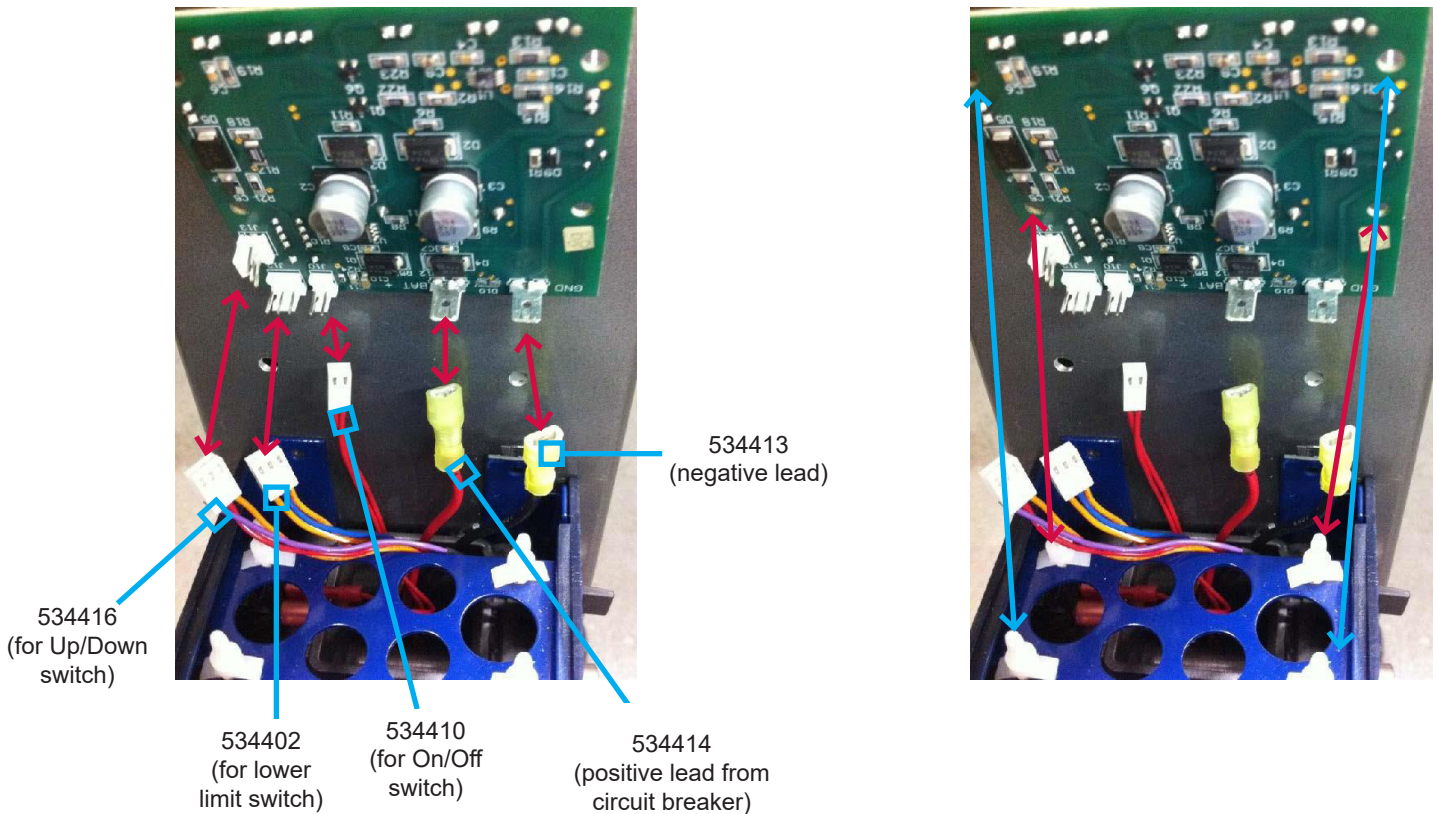



**Control Board Diagram - Top**

Wiring harnesses are connected to the top side of the control board as shown below.

Upper limit switch wiring harnesses:  
 • 48" units - 534401  
 • 60" units - 534405  
 • 72" units - 534406

Motor wires (part of motor)  
 (black, red)

Motor wire extensions (60" and 72" units):

- 60" units -
- Positive lead extension - 534417
- Negative lead extension - 534418
- 72" units -
- Positive lead extension - 534419
- Negative lead extension - 534420

Solenoid adapter harness:

- 48" units - 534421
- 60" units - 534422
- 72" units - 534423

Not used

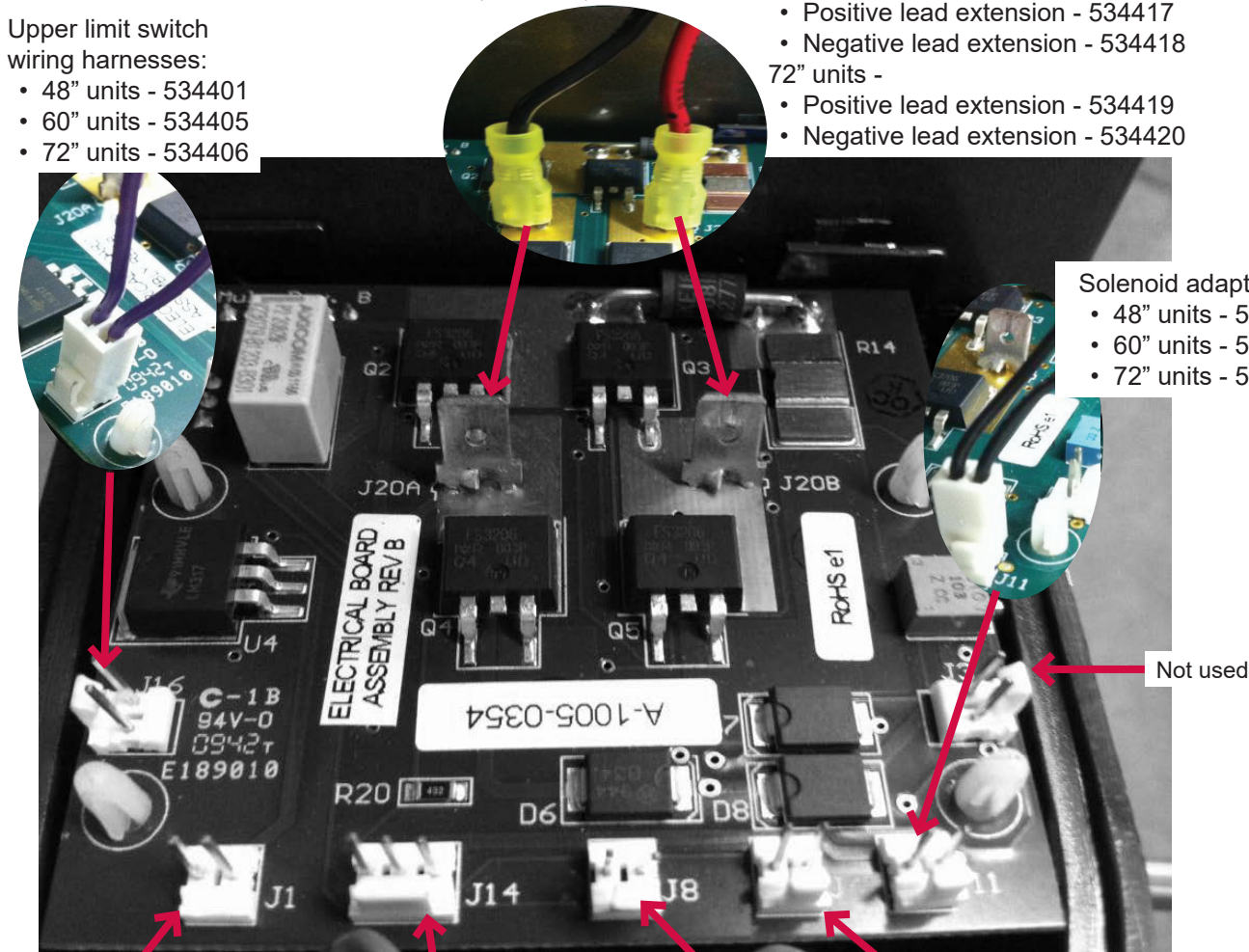

534408  
 (charger input)

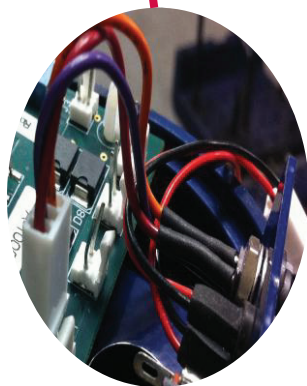

534409  
 (remote input)

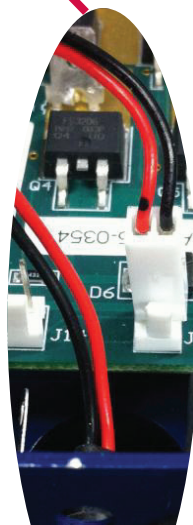

534411  
 [charging light (green)]

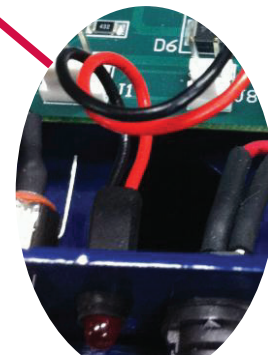

534412  
 [overload light (red)]

## Maintenance

Area	Inspection Frequency	Procedure/Normal Condition
Outside Surfaces	Daily	Keep clean and dry. Replace any cracked or missing covers.
Fasteners	Daily	Tighten any loose hardware.
Battery Charging	Daily	Green charging light should turn on when charging.
Rear Wheels	Daily	Inspect wheels and tires for wear and cracks.
Front Casters	Daily	Inspect for wear; clean dirt and debris.
Rolling Function	Daily	Unit should roll easily in all directions: forward/backward and left/right
Brake Lever	Daily	Brake lever should move freely up and down; lock lever should hold brake lever in locked (squeezed) position.
Brake Tension	Daily	Braking power should be sufficient; if not, adjust as necessary (see Brakes section). To test - squeeze the brake lever tightly, tilt the unit back about 35° and try to push the unit. Wheels should not spin when holding the brakes tightly.  It is normal for brakes to rub slightly, but it should not be enough to interfere with easy rolling of the unit.
Trolley	Daily	Inspect for wear or damage. Trolley should move up and down smoothly within the lift assembly.
Lift Screw	Daily	Inspect before each use; keep free of dirt and debris. Lifting and lowering motions should be smooth.
Attachments/ Accessories	Daily	Inspect for wear and damage; replace as needed.
Folding Linkage Assembly	Weekly	The unit should fold and unfold smoothly. Locking latch should fully lock into place; see section Unfolding the Unit for photos.
Battery Connections	Weekly	Tighten any loose connections to the battery terminals. Check for any cracked or damaged wires; replace parts as needed.
Lift Screw Lubrication	Weekly for first month; Monthly after first month.	Lubricate with a plastic-safe multi-purpose precision lubricant such as CRC Industrial Technical Grade 3-36. <ol style="list-style-type: none"> <li>1. Place absorbent towel underneath the unit.</li> <li>2. Spray length of lift screw, the center trolley surface, and front and rear plastic wheel shafts (see next page for diagram). It does not need to be soaked, just enough so it spreads on the surfaces.</li> <li>3. Lift and lower unloaded attachment for 5 full cycles to distribute lubricant.</li> </ol>

Lubrication Points

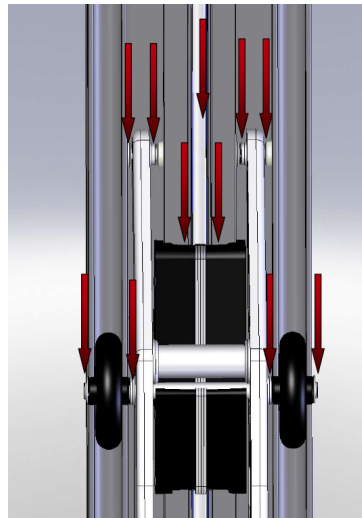

**Troubleshooting Guide**

Problem	Solution(s)
The lift does not respond, and does not make any noise when the lift switch is activated.	<ol style="list-style-type: none"> <li>1. Is the power switch turned on?</li> <li>2. Has the circuit breaker tripped?</li> <li>3. Check the battery connections.</li> <li>4. Recharge the battery.</li> <li>5. Replace the battery.</li> </ol>
The lift struggles to raise objects and works very slowly.	<ol style="list-style-type: none"> <li>1. Check for dirt or other obstruction around the lift screw.</li> <li>2. Recharge the battery.</li> <li>3. Replace the battery.</li> </ol>
The lift will not rise for more than a second, but it will lower.	<ol style="list-style-type: none"> <li>1. If the red light is on, you may have exceeded the weight limit. Try less weight.</li> <li>2. Lower the lift all the way to the bottom and the red light should go out, resetting the protection circuit.</li> <li>3. Check for dirt or other foreign materials in the lift mechanisms and for interference of the lifting attachment with other objects. If the lift is obstructed, this may activate the overload protection circuit. To reset the circuit, repeat Step 2.</li> </ol>
The unit is very difficult to roll.	<ol style="list-style-type: none"> <li>1. Check that the parking brake is not engaged.</li> <li>2. Lift the lifting attachment and inspect the front casters for obstructions.</li> <li>3. Inspect the brake pads and brake rotors for obstructions.</li> <li>4. Adjust the brake calipers. Details on page 11.</li> </ol>
The brakes do not work at all or work adequately.	<ol style="list-style-type: none"> <li>1. Adjust the brake cable tension. Details on page 10.</li> <li>2. Adjust the brake calipers. Details on page 11.</li> </ol>
The unit will not charge.	<ol style="list-style-type: none"> <li>1. Check to make sure the charger is fully plugged into the outlet and the charging port of the unit.</li> <li>2. Check that the circuit breaker is not tripped.</li> <li>3. Check that the battery is connected.</li> </ol>

## Advanced Troubleshooting Guide

### *How do I know if the battery needs to be replaced?*

Indications that it might need replacement:

- Does not hold a charge
- Slower lift speed
- Grinding noise
- Unit won't lift at all
- Shorter time in between charging
- Battery is leaking

Diagnostic Instructions:

1. Check the charger with a multi-meter set to Volts DC. Place the positive lead in the center of the adapter and touch the negative lead to the outside (Figure 1). Voltage should read 15V or higher when plugged into an AC outlet.
2. Remove the battery cover and remove wires from the terminals; measure the voltage across the wires when the charger is plugged into the LiftPlus and the AC outlet (Figure 2). Should read approximately 15V. This means power is getting from the control board to the wire terminals. NOTE: This voltage may have slightly lower readings because the controller will limit charge getting to battery in relation to how much "charge" is in the battery - the higher the battery charge, the lower the voltage going in. This permits you to leave the charger plugged into the LiftPlus as often as you'd like without overcharging it.
3. With the terminal wires still removed from the battery, measure the voltage across the battery terminals (Figure 3). Ideally the battery should read 12 to 12.6V.
4. If the voltage is lower than 12V:
  - Charge overnight.
  - After charging, check voltage across battery terminals:
    - Under 12V - replace battery
    - 12 to 12.6V - Normal
  - Place a load on the LiftPlus and run up and down a few cycles. If voltage drops from 12V, you should replace the battery.



Figure 1

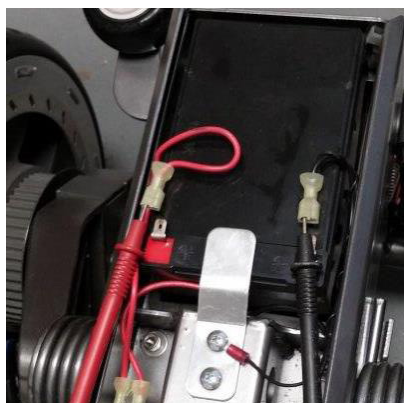

Figure 2

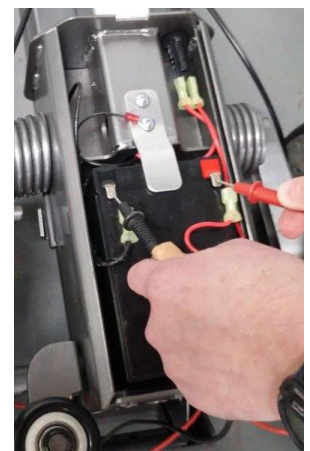

Figure 3



**How do I test switch functionality?**

Please use caution when removing covers and exposing moving parts.

Diagnostic Instructions:

1. Remove battery cover and remove the wires from the battery terminals. Hook Multi-Meter to wire terminals and set range to Kilo-Ohms.

2. Check Power Switch

- OFF
  - Make sure power switch is turned OFF.
  - Record the reading. Example in picture is 84.7 K-Ohms.
- ON
  - Good: Turn power switch on and if the power switch and breaker are functioning properly then the meter will read a lower resistance. Example in picture is 1.158 K-Ohms.
  - Bad: If the power switch or overload circuit is bad, then the reading will not change.
  - Check the overload circuit for continuity:
    - Place the black power lead on the LH circuit terminal and the red power lead on the RH terminal. A functioning overload circuit will show 0 K-Ohms.
    - If the overload circuit is good, then replace the power switch.



3. Check Up/Down Switch

- Make sure power switch is turned ON.
- Up
  - Good: Press the Up/Down switch to Up and the meter will read a lower resistance. Example in picture is .1253 K-Ohms (or 125.3 Ohms).
  - Bad: If no change in meter, check the wire connections. If the wires are properly connected, then replace the Up/Down switch.
- Down
  - Press the Up/Down switch to Down and the meter will read a lower resistance. Example in picture is .2449 K-Ohms (or 244.9 Ohms).
  - Bad: If no change in meter, check the wire connections. If the wires are properly connected, then replace the Up/Down switch.



4. Check Control Board

- If the switches are operating correctly, then determine whether the terminals on top of the control board are getting power to the motor.
- Remove the top covers from the LiftPlus. Remove the Multi-Meter from the battery and reconnect the battery. Change the range on the Multi-Meter to volts.
- Connect the Multi-Meter to the motor terminals on the control board.

Readings should be:

- 0 volts when switch is OFF
- 12 volts when switch is ON and Up/Down switch is pressed Up or Down.
- If there is no voltage on the motor terminals when there should be, contact Magline.

Motor Terminals

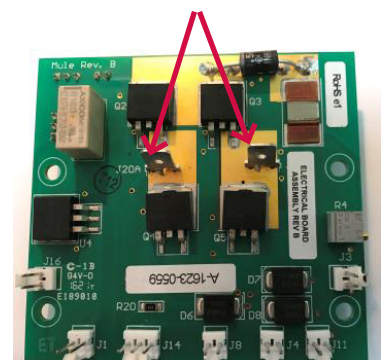

**The motor works in only one direction.**

Please use caution when removing covers and exposing moving parts.

Please try these steps first:

- Check for dirt and other obstructions
- Lubricate the lift screw; see pages 13-14 for instructions.

Diagnostic Instructions:

1. Remove the motor cover from the LiftPlus. Check the wire connections to the upper and lower switches and the board. Fix any loose connections; replace any damaged wiring.
  - If it will lift, but not lower - check upper limit switch (see Step 2); replace if needed
  - If it will lower, but not lift:
    - Check overload circuit - reset if needed
    - Check lower limit switch (see Step 2); replace if needed
2. Check switch continuity - set multimeter to Continuity Test mode
  - Upper limit switch
    - Unplug the wire from the NC terminal on the switch (see diagram below)
    - Place the black power lead on the common terminal; place the read power lead on the NC terminal on the side of the switch. A properly working switch will show continuity when the red lead is on the NC terminal AND the switch is not depressed. It will show incomplete circuit (open circuit) when the read lead is touched to the NO terminal on the side of the switch AND the switch is not depressed.
    - Replace if the switch is damaged.
  - Lower limit switch
    - Unplug the wire from the NC terminal on the switch (see diagram below)
    - Place the black power lead on the common terminal; place the read power lead on the NC terminal on the side of the switch. A properly working switch will show continuity when the red lead is on the NC terminal AND the switch is not depressed. It will show incomplete circuit (open circuit) when the read lead is touched to the NO terminal on the side of the switch AND the switch is not depressed.
    - Replace if the switch is damaged.
  - Up/Down switch (see page 16)
3. If the switches are operating correctly, then determine whether the terminals on top of the control board are getting power to the motor.
  - Connect the Multi-Meter to the motor terminals on the control board. Set the Multi-Meter range to volts. Readings should be:
    - 0 volts when switch is OFF
    - 12 volts when switch is ON and Up/Down switch is pressed Up or Down.
  - If the motor still only moves in one direction, contact Magline.

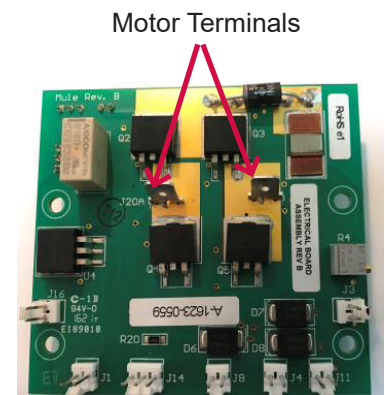
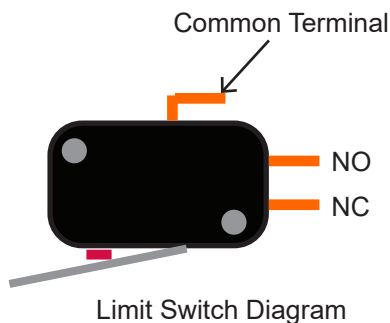

Accessories	Part Number
Work bench (includes platform, vice clamps, vice handle and back bar)	536020
Quick change adapter (for use with 536020 work bench only)	536026
Arbor - 24" long x 1.66" diameter	536039
Adjustable boom with chain/hook assembly (requires arbor attachment)	536088
Bent Forks - 21" wide x 18" long, 3.5" height from floor	536044
Straight Forks - 18.5" wide x 18.5" long, 5" height from floor	536053
Straight Forks - 21" wide x 18" long, 5" height from floor	536060
Straight Forks - 20" wide x 32" long, 5" height from floor	536048
Anti-slip rubber kit for forks	536086
V-Tray (requires 18.5" wide x 18.5" long forks)	536054
Steel Pallet - 24" wide x 24" long (requires either 21" wide fork attachment)	536025
Steel Pallet - 34" wide x 34" long (requires the 20" wide fork attachment)	536033
Steel Pallet with sides - 21.5" wide x 19" long (requires the 21" wide straight fork attachment)	536103
Pail Lifter - accommodates three 5-gallon pails	536093
Tethered remote control	534200
External battery charger	63027
Tote bag	534500
Parts	Part Number
Axle, front roller	22145
Front roller	531708
Axle, rear roller	22146
Rear roller	531709
Battery - 12V-15.0 Ah	61017
Battery cover	533501
Brake cable assembly - 14" chassis	532134
Brake caliper assembly	532100
Button, molded black	80813
Caster shell - LH	532503
Caster shell - RH	532504
Caster, assembly with plate only	532500
Caster, complete assembly in shell	530000
Charger assembly, 12V with U.S. blade plug	63030
Circuit breaker - 15A, 32VDC, 250 VAC (includes power supply wiring harness)	534415
Electrical board	63025

Parts	Part Number
Limit switch (used for upper and lower)	62067
Lock washer for circuit breaker	80799
Motor assembly - high speed (includes motor, mounting bracket, solenoid and brake)	534101
Motor assembly - standard speed (includes motor, mounting bracket, solenoid and brake)	534100
Motor cover	533505
Nut, trolley drive	531705
Pulley assembly #1 (top gear)	534106
Pulley assembly #2-3 with bearings (includes one 534107 and two 534115)	534123
Pulley 2-3 assembly	534107
Flanged bearing - .250 ID x .375 OD x .38" long	534115
Pulley assembly #4 (lower)	531117
Switch - On/Off (includes wiring harness)	534410
Switch - Up/Down (includes wiring harness)	534416
Timing belt - 5mm pitch x 15mm W x 60 grooves	534118
Top cover assembly	533502
Trolley assembly	531700
Tune-up kit	534300
Wiring harness for lower limit switch	534402
Wiring harness for upper limit switch - 48" models	534401
Wiring harness for upper limit switch - 60" models	534405
Wiring harness for upper limit switch - 72" models	534406
Wiring harness for negative power (ground)	534413
Wiring harness for positive power	534414
Wiring harness extension for positive motor lead - 60" models	534417
Wiring harness extension for negative motor lead - 60" models	534418
Wiring harness extension for positive motor lead - 72" models	534419
Wiring harness extension for negative motor lead - 72" models	534420
Wiring harness - adapter for motor solenoid - 48" models	534421
Wiring harness - adapter for motor solenoid - 60" models	534422
Wiring harness - adapter for motor solenoid - 72" models	534423
Wiring harness/connector assembly for remote control input	534409
Wiring harness/connector assembly for power jack (charger input)	534408
Wiring harness for green charging light	534411
Wiring harness for red overload light	534412
Wheel and tire assembly	532310
Work bench vise	536018









**MAGLINE® INC.**

**1205 West Cedar Street**

**Standish, Michigan 48658**

**1-800-MAGLINE (624-5463)**

**Email: [customerservice@magliner.com](mailto:customerservice@magliner.com)**

**[www.magliner.com](http://www.magliner.com)**