

NARROW AISLE - E, G & K Series Nose Mounting Bracket

PARTS LIST

Item	Description	Qty.	Part No.
-	Mounting Bracket Kit for Narrow Aisle Hand Truck (includes items below)	-	86094
A	Nose mounting bracket for Narrow Aisle Hand Truck	2	210118
B	Carriage bolt - 5/16"-18 x 1" long	4	80144
C	Hex lock nut - 5/16"-18	4	80676

TOOLS REQUIRED
• (1) 1/2" WRENCH

THIS ASSEMBLY SEQUENCE IS RECOMMENDED

- Assemble the mounting brackets (refer to illustrations below):
 - Position one mounting bracket (A) on the hand truck nose
 - Align the square holes in the mounting bracket and nose; insert two 5/16"-18 x 1" long carriage bolts (B) through the nose into the mounting brackets and thread on two 5/16"-18 hex lock nuts (C). DO NOT TIGHTEN THE HEX LOCK NUTS UNTIL THE NOSE IS ASSEMBLED TO THE HAND TRUCK.
- Repeat the above assembly sequence for the second mounting bracket
- Attach nose to hand truck frame rails using 5/16" dia. hex head cap screw (not included)
- Once the nose assembly is assembled to the hand truck, check/adjust component alignment, then tighten the 5/16" carriage bolts/hex lock nuts to 120-140 in. lbs.

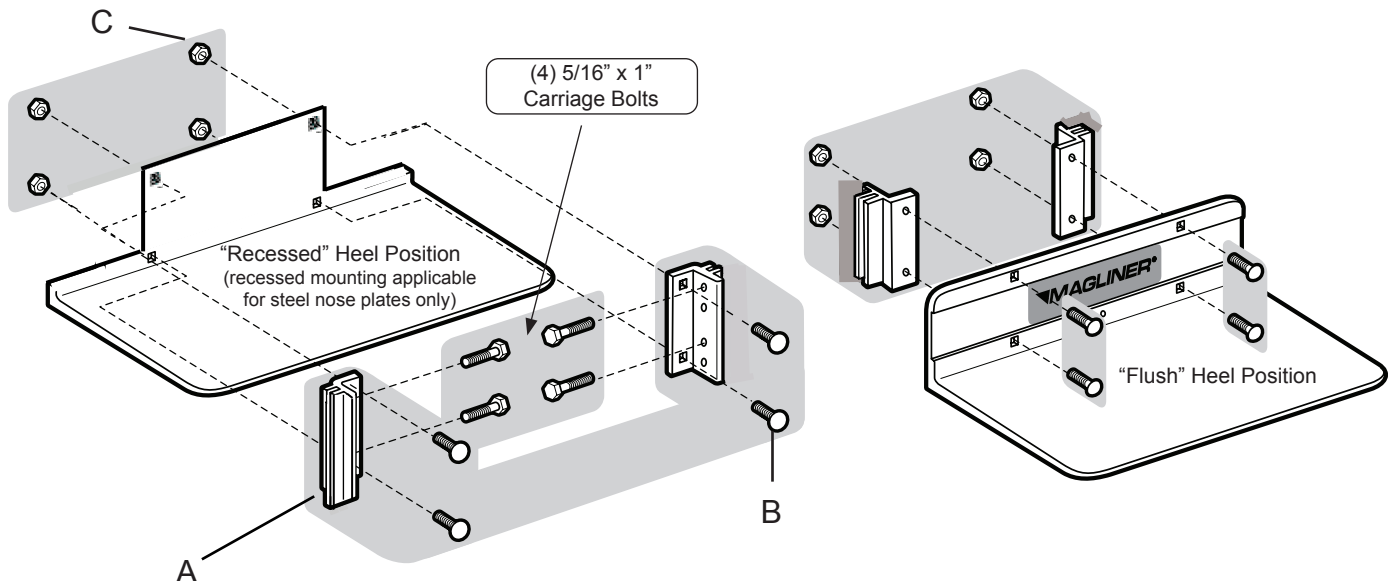

MAGLINER®

www.magliner.com

Magline, Inc., 1205 West Cedar Street, Standish, MI 48658 • (800) 624-5463 • (989) 512-1000