

# E, G & K Series Nose Mounting Bracket

## PARTS LIST

Item	Description	Qty.	Part No.
-	Mounting Bracket Kit (includes items below)	-	86029
A	Nose mounting bracket	2	210107
B	Carriage bolt - 5/16"-18 x 1" long	4	80144
C	Hex lock nut - 5/16"-18	4	80676

**TOOLS REQUIRED**  
• (1) 1/2" WRENCH

## THIS ASSEMBLY SEQUENCE IS RECOMMENDED

1. Assemble the mounting brackets (refer to illustrations below):
  - a. Position one mounting bracket (A) on the back of the hand truck nose
  - b. Align the square holes in the mounting bracket and nose; insert two 5/16"-18 x 1" long carriage bolts (B) through the nose into the mounting brackets and thread on two 5/16"-18 hex lock nuts (C). DO NOT TIGHTEN THE HEX LOCK NUTS UNTIL THE NOSE IS ASSEMBLED TO THE HAND TRUCK.
2. Repeat the above assembly sequence for the second mounting bracket
3. Attach nose to hand truck frame rails using 5/16" dia. hex head cap screw (not included)
4. Once the nose assembly is assembled to the hand truck, check/adjust component alignment, then tighten the 5/16" carriage bolts/hex lock nuts to 120-140 in. lbs.

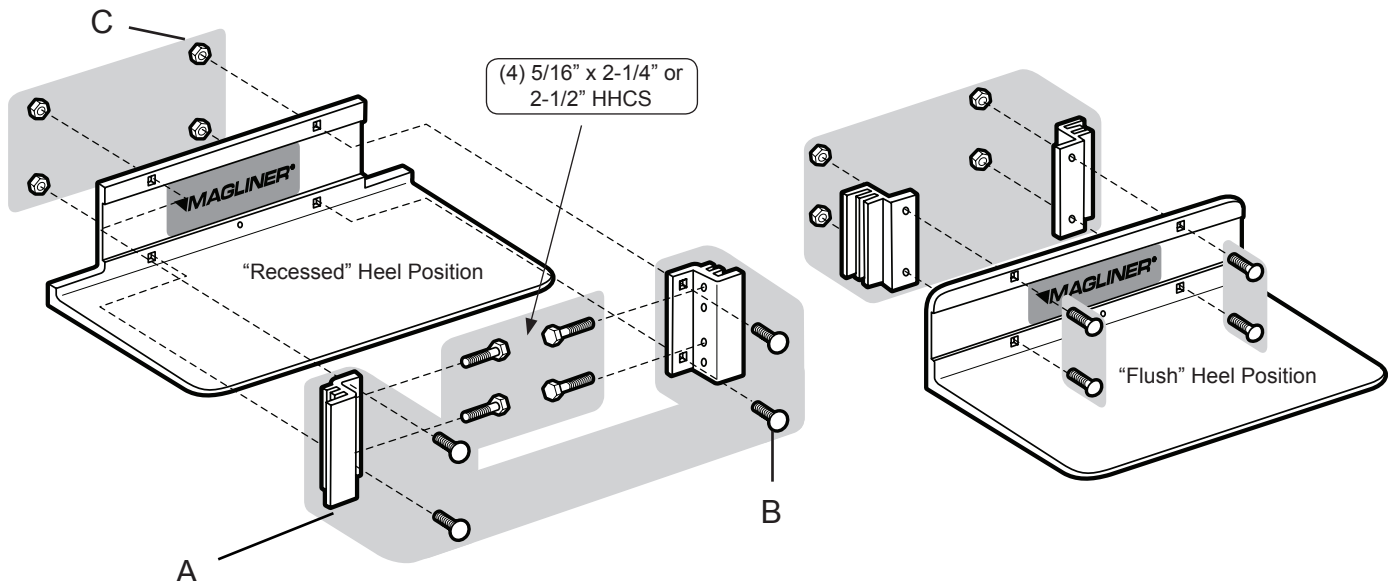

**MAGLINER®**

[www.magliner.com](http://www.magliner.com)

Magline, Inc., 1205 West Cedar Street, Standish, MI 48658 • (800) 624-5463 • (989) 512-1000